

Report

September 2018 Flood

The scanned documents in this digital file were part of the original SCDOT paper files for the flood of interest. Some of these documents will have more pertinent information regarding the flood than others, but all paper documents were, generally, included for historical documentation.

List of Documents

- USGS Preliminary Peak Stage and Streamflow Data
- SCDOT Pee Dee River Basin Bridge Evaluation

Preliminary Peak Stage and Streamflow Data at Selected U.S. Geological Survey Streamgaging Stations in North and South Carolina for Flooding Following Hurricane Florence, September 2018

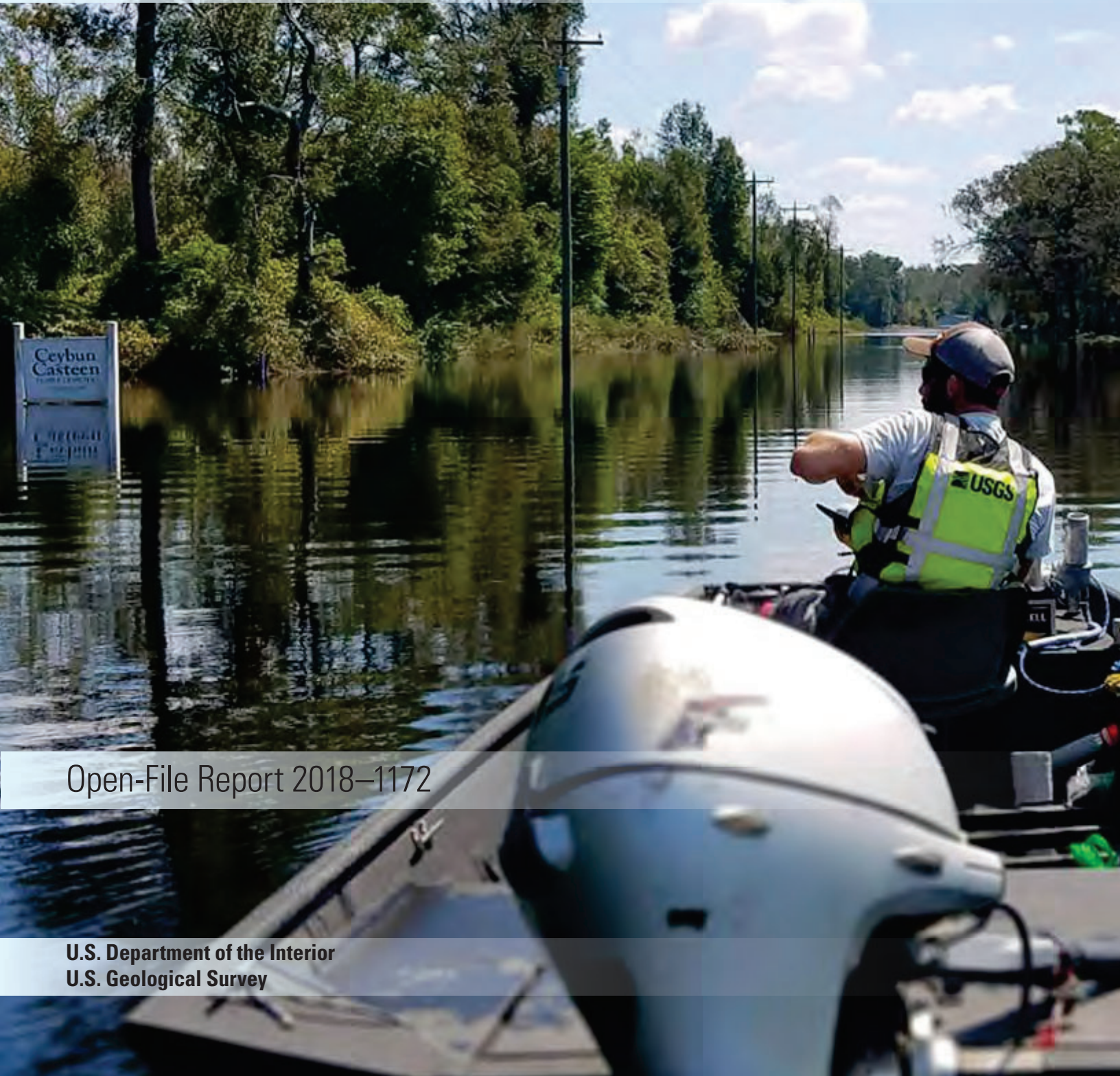

Open-File Report 2018–1172

Cover. Front cover photograph is a U.S. Geological Survey hydrographer navigating flood waters in Duplin County, North Carolina, in an effort to install a rapid-deployment gage to monitor rising flood waters (back cover photograph), September 20, 2018. Photographs by Daniel McCay, USGS.

Preliminary Peak Stage and Streamflow Data at Selected U.S. Geological Survey Streamgaging Stations in North and South Carolina for Flooding Following Hurricane Florence, September 2018

By Toby D. Feaster, J. Curtis Weaver, Anthony J. Gotvald, and Katharine R. Kolb

Open-File Report 2018–1172

**U.S. Department of the Interior
U.S. Geological Survey**

U.S. Department of the Interior
RYAN K. ZINKE, Secretary

U.S. Geological Survey
James F. Reilly II, Director

U.S. Geological Survey, Reston, Virginia: 2018

For more information on the USGS—the Federal source for science about the Earth, its natural and living resources, natural hazards, and the environment—visit <https://www.usgs.gov> or call 1–888–ASK–USGS.

For an overview of USGS information products, including maps, imagery, and publications, visit <https://store.usgs.gov>.

Any use of trade, firm, or product names is for descriptive purposes only and does not imply endorsement by the U.S. Government.

Although this information product, for the most part, is in the public domain, it also may contain copyrighted materials as noted in the text. Permission to reproduce copyrighted items must be secured from the copyright owner.

Suggested citation:

Feaster, T.D., Weaver, J.C., Gotvald, A.J., and Kolb, K.R., 2018, Preliminary peak stage and streamflow data at selected U.S. Geological Survey streamgaging stations in North and South Carolina for flooding following Hurricane Florence, September 2018: U.S. Geological Survey Open-File Report 2018–1172, 36 p., <https://doi.org/10.3133/ofr20181172>.

ISSN 2331-1258 (online)

Contents

Abstract	1
Introduction.....	1
Purpose and Scope	5
Study Area.....	5
General Weather Conditions and Precipitation Causing the September 2018 Flooding.....	5
Methods.....	7
Flood Exceedance Probabilities of Peak Streamflows.....	9
Peak Streamflows and Stages	10
Estimated Magnitudes and Flood Exceedance Probabilities of Peak Streamflows.....	11
Comparison to Past Floods.....	16
Summary.....	23
References Cited.....	24

Figures

1. National Oceanic and Atmospheric Administration satellite image of Hurricane Florence as it made landfall on September 14, 2018.....	2
2. The track of Hurricane Florence through the Atlantic Ocean from August 30 through September 18, 2018.....	2
3. Accumulated precipitation during Hurricane Florence for September 13–18, 2018	3
4. U.S. Geological Survey Real-Time Data Network for the United States	4
5. Selected U.S. Geological Survey real-time streamgages and major physiographic provinces in North and South Carolina	6
6. U.S. Geological Survey personnel use an acoustic Doppler current profiler to make a streamflow measurement of flood waters from the Cape Fear River in Kelly, North Carolina, on September 20, 2018	7
7. Rating curve developed for use before and after the September 2018 flood for Little River at Manchester in northern Cumberland County, N.C., showing streamflow measurements made during the event	8
8. U.S. Geological Survey rapid deployment gage at Trent River at U.S. Highway 70 at New Bern, N.C., September 20, 2018	8
9. U.S. Geological Survey field crews conducting surveys of high-water marks to document the depth of flood waters near Northeast Creek in Piney Green in Onslow County, N.C., for the September 2018 flood	9
10. Flood-frequency curve for the annual peak streamflows at U.S. Geological Survey streamgage 02109500, Waccamaw River at Freeland, N.C.	10
11. Peak streamflows for the period of record and the peak streamflow from Hurricane Florence at U.S. Geological Survey streamgage 02135000, Little Pee Dee River at Galivants Ferry, S.C.....	16
12. Peak streamflows for the period of record and the peak streamflow from Hurricane Florence at U.S. Geological Survey streamgage 02109500, Waccamaw River at Freeland, N.C.....	17
13. Annual peak flows at U.S. Geological Survey streamgage 02169500, Congaree River at Columbia, S.C.	17

- 14. Annual peak streamflows at U.S. Geological Survey streamgage 02197000, Savannah River at Augusta, Georgia18
- 15. Daily mean streamflows at U.S. Geological Survey streamgage 02197000, Savannah River at Augusta, Georgia, for September 21, 1929, to October 8, 1929.....19
- 16. Annual peak streamflows at U.S. Geological Survey streamgage 03451500, French Broad River at Asheville, N.C.20

Tables

- 1. Preliminary peak stage and streamflow data at streamgages in North and South Carolina with at least 10 years of record and where new or top 5 peak-streamflow records were set during the flood of September 2018 following Hurricane Florence.....27
- 2. Selected recurrence intervals and the associated annual exceedance probabilities....9
- 3. Site identification number, station number, and weighted estimated peak streamflows for selected annual exceedance probabilities with 95-percent confidence intervals at selected U.S. Geological Survey streamgages in North Carolina and South Carolina12
- 4. Peak gage heights, peak streamflows, and estimated annual exceedance probabilities for the September 2018 Hurricane Florence related-flood event at selected U.S. Geological Survey streamgages in North and South Carolina.....15
- 5. Chronology of major floods in North Carolina since 1876 and in South Carolina since 1893.....20

Conversion Factors

U.S. customary units to International System of Units

Multiply	By	To obtain
Length		
foot (ft)	0.3048	meter (m)
mile (mi)	1.609	kilometer (km)
Area		
square mile (mi ²)	259.0	hectare (ha)
square mile (mi ²)	2.590	square kilometer (km ²)
Flow rate		
foot per second (ft/s)	0.3048	meter per second (m/s)
cubic foot per second (ft ³ /s)	0.02832	cubic meter per second (m ³ /s)

Datum

Horizontal coordinate information is referenced to either the North American Datum of 1927 (NAD27) or the North American Datum of 1983 (NAD83).

Preliminary Peak Stage and Streamflow Data at Selected U.S. Geological Survey Streamgaging Stations in North and South Carolina for Flooding Following Hurricane Florence, September 2018

By Toby D. Feaster, J. Curtis Weaver, Anthony J. Gotvald, and Katharine R. Kolb

Abstract

Hurricane Florence made landfall as a Category 1 hurricane at Wrightsville Beach, North Carolina, shortly after dawn on September 14, 2018. Once over land, the forward motion of the hurricane slowed to about 2 to 3 miles per hour. Over the next several days, the hurricane delivered historic amounts of rainfall across North and South Carolina, causing substantial flooding in many communities across both States. For the Hurricane Florence event, a new record rainfall total of 35.93 inches was set in Elizabethtown, N.C. Many other locations throughout North Carolina set new records for rainfall, exceeding the previous State record for rainfall from a tropical system of 24.06 inches, which was set over a 4-day period in Southport, N.C., during Hurricane Floyd in 1999. In South Carolina, the highest reported total rainfall of 23.63 inches was in Loris, S.C., which was the highest total rainfall in South Carolina from a tropical cyclone, replacing the previous total of 17.45 inches associated with Tropical Storm Beryl in 1994. During the October 2015 flood in South Carolina, a 4-day total rainfall of 26.88 inches was recorded in Mount Pleasant; however, because that total rainfall was a combination of a tropical storm system and another front that was centered over the State, it is not considered the largest rainfall event from a tropical storm.

Peak streamflow and stage data at 84 U.S. Geological Survey streamflow gaging stations (referred to hereafter as streamgages) in North and South Carolina with at least 10 years of systematic record and for which the flooding following Hurricane Florence resulted in a peak in the top 5 for the period of record are included in this report. New peak streamflows of record were recorded at 18 sites in North Carolina and 10 sites in South Carolina. Another 49 streamgages recorded peak streamflows in the top 5 for their record (45 in North Carolina and 4 in South Carolina). Peak streamflow data following Hurricane Florence were not available for three additional streamgages prior to the publication of this report. Of those three streamgages, two recorded a new peak stage of record and one recorded the second highest peak stage of

record. An additional four stage-only streamgages having at least 10 years of systematic record also had new peak stages (also referred to as gage height) of record. For 11 of the 28 streamgages for which the September 2018 peak streamflow was the peak of record, the October 2016 peak following Hurricane Matthew was the second largest peak, and for another four streamgages the September 1999 peak following Hurricane Floyd was the second largest peak.

For the 28 streamgages for which a new peak streamflow of record was recorded, a flood-frequency analysis was done using available systematic record through September 2017 and the peak streamflow from the Hurricane Florence event. Of the 28 streamgages analyzed, the estimated annual exceedance probability for the Hurricane Florence peak streamflow at 9 of the streamgages was less than 0.2 percent, which in terms of recurrence intervals is greater than a 500-year flood event. At three streamgages, the estimated annual exceedance probability was equal to 0.2 percent, and at six streamgages, it was between 0.2 and 1 percent (between a 500- and 100-year recurrence interval, respectively). For the remaining 10 streamgages, the estimated annual exceedance probability was between 1.5 and 7.1 percent, which in terms of recurrence intervals is approximately a 67- to 14-year event, respectively.

Introduction

Early Friday morning on September 14, 2018, Hurricane Florence made landfall as a Category 1 hurricane at Wrightsville Beach, North Carolina (North Carolina Department of Public Safety, 2018) with a zone of tropical storm force winds nearly 400 miles wide (Samenow, 2018) (fig. 1). Two weeks earlier on August 30, 2018, the storm originated as a strong tropical wave off the west coast of Africa (National Oceanic and Atmospheric Administration, 2018). By Saturday September 1, the storm had been upgraded to Tropical Storm Florence and continued its westward movement (fig. 2). During September 4–5, the storm became a Category 4 hurricane

2 Preliminary Peak Stage and Streamflow Data at USGS Streamgages in N.C. and S.C. Following Hurricane Florence

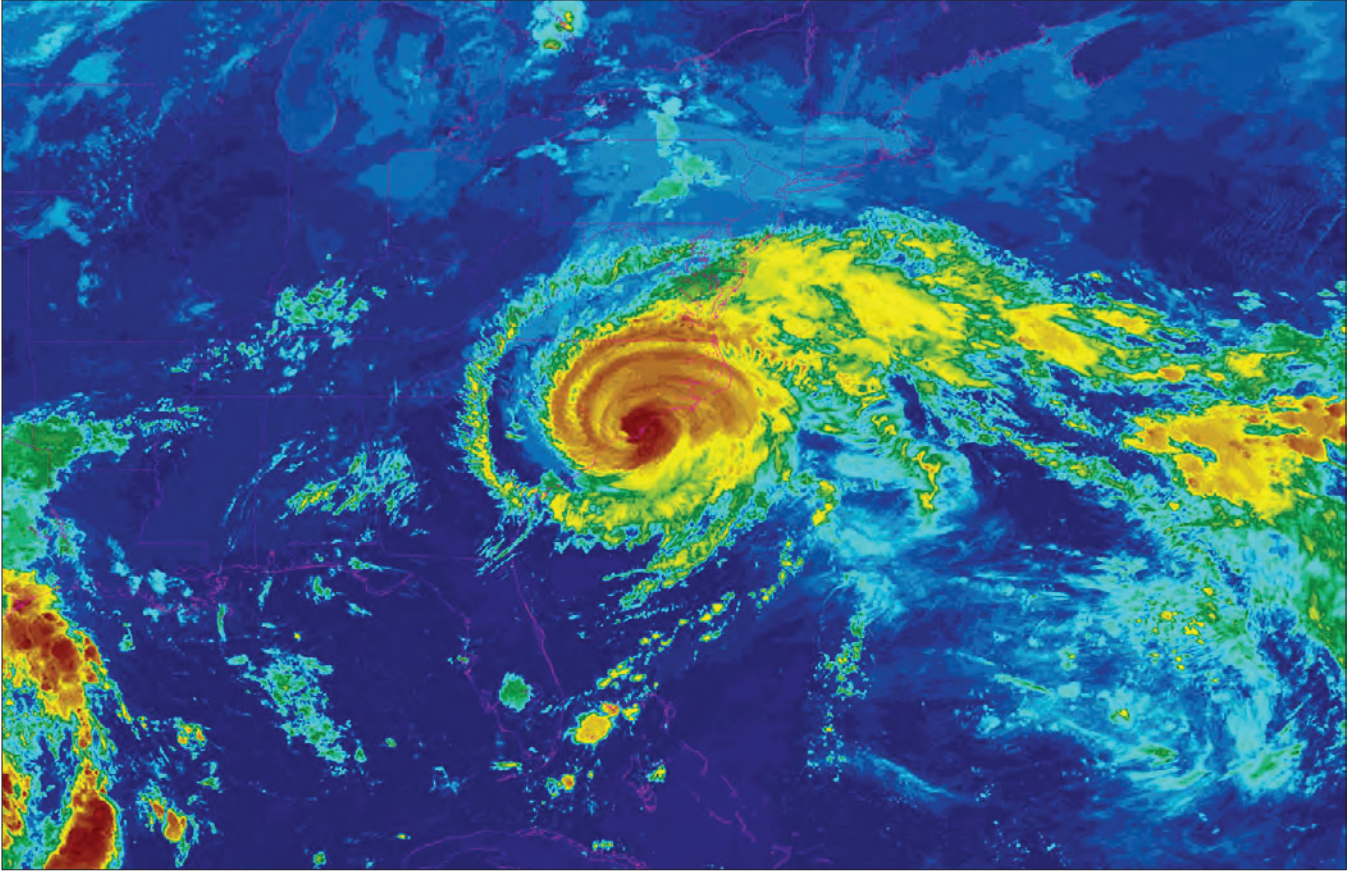

Figure 1. National Oceanic and Atmospheric Administration satellite image of Hurricane Florence as it made landfall on September 14, 2018 (Ashley Hiatt, North Carolina State Climate Office, written commun., October 4, 2018).

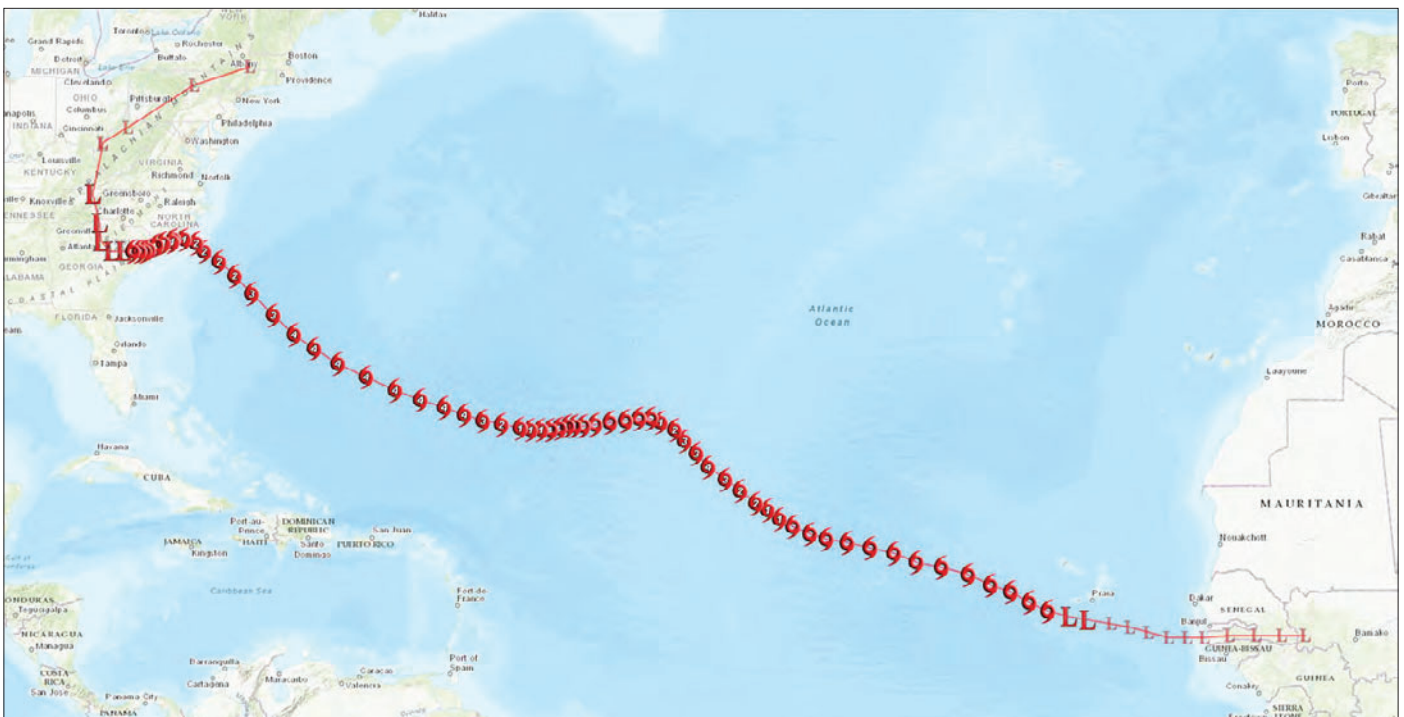

Figure 2. The track of Hurricane Florence through the Atlantic Ocean from August 30 through September 18, 2018 (Ashley Hiatt, North Carolina State Climate Office, written commun., October 4, 2018).

with maximum sustained winds of 130 miles per hour. In the following days, Florence continued to move north-northwest and encountered areas of high wind shear that reduced and weakened the storm; following periods of strengthening, the hurricane made landfall as a Category 1 hurricane (State Climate Office of North Carolina, 2018a).

As Hurricane Florence moved inland, the forward motion slowed to about 2 to 3 miles per hour producing large amounts of rain across the Carolinas (fig. 3). The maximum 4-day rainfall total reached almost 36 inches in some areas of North Carolina and almost 24 inches in some areas of South Carolina, resulting in historic flooding in many communities within both States. As of September 20, the death toll related to Florence had risen to 42 even as some of the major rivers in the Carolinas continued to rise as flood waters drained toward the Atlantic Ocean (CBS News, 2018). Duke Energy reported nearly 1.8 million power outages in the Carolinas but worked rapidly to restore power throughout the region. By Sunday night September 23, the utility company anticipated having power restored to 99 percent of their

customers (Duke Energy, 2018). By Friday September 21, more than 820 roads in the Carolinas were still closed with 169 in South Carolina and 656 in North Carolina, including sections of Interstates 40 and 95 (Alexander and others, 2018).

Initial estimates of total property damage in North Carolina from Hurricane Florence are in the range of \$22 billion (National Grain and Feed Association, 2018) with initial estimates of crop damage and livestock losses expected to surpass \$1.1 billion (Sweat, 2018). The North Carolina Department of Agriculture and Consumer Services preliminary estimates indicated livestock losses at 3.4 million poultry and 5,500 hogs. In South Carolina, Governor Henry McMaster estimated damages from Florence to exceed \$1.2 billion (Smith, 2018). South Carolina agricultural losses are estimated to be close to \$125 million, cotton being the hardest hit crop with preliminary estimates of as much as \$56 million (Hart, 2018).

In addition to the catastrophic flooding from Hurricane Florence, the coastal and central parts of North and South Carolina experienced previous catastrophic flooding in 2016

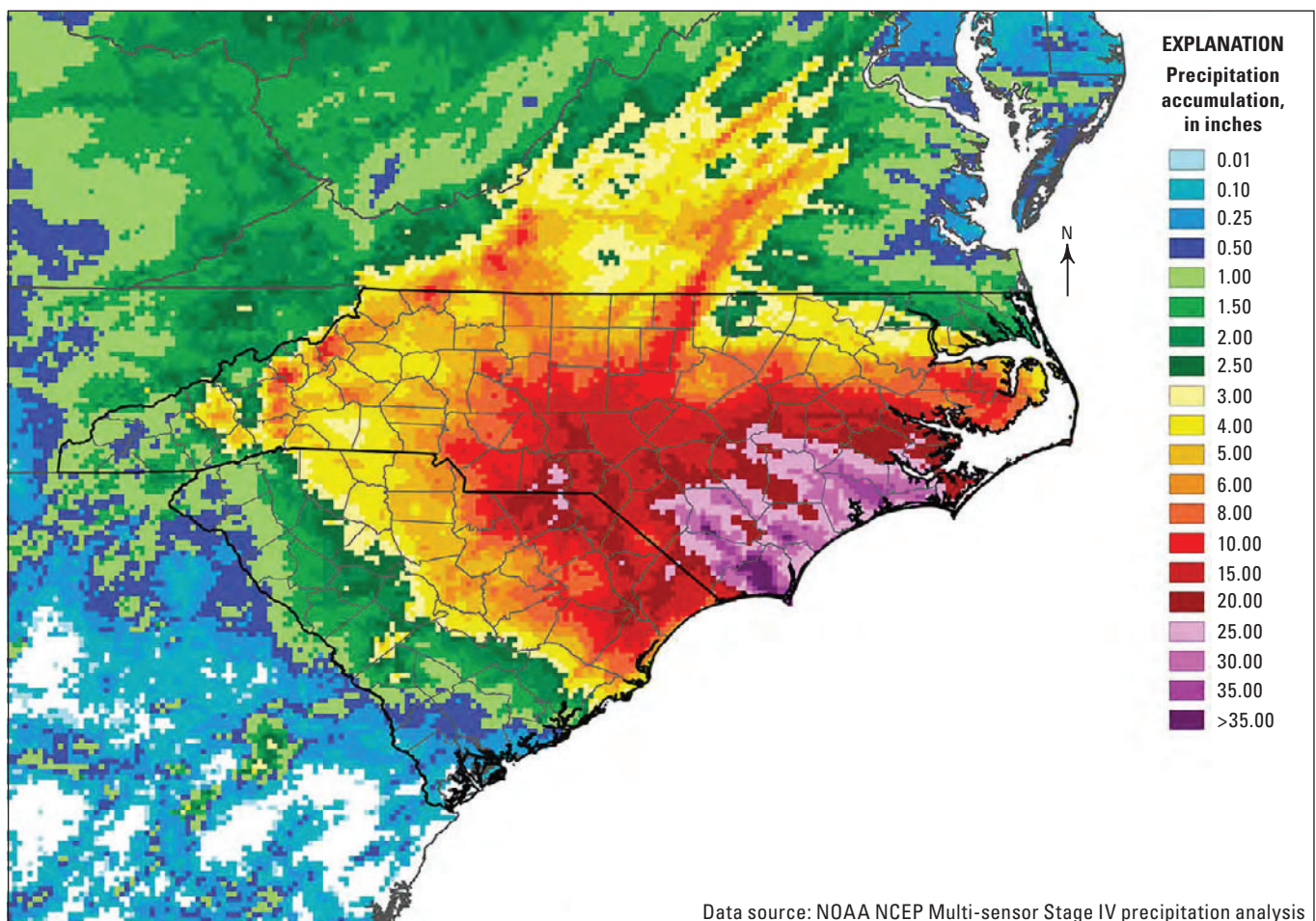

Figure 3. Accumulated precipitation in North and South Carolina and surrounding States during Hurricane Florence for September 13–18, 2018 (Rebecca Ward, North Carolina State Climate Office, written commun., October 3, 2018).

4 Preliminary Peak Stage and Streamflow Data at USGS Streamgages in N.C. and S.C. Following Hurricane Florence

and 2015 from two other tropical events. In October 2016, Hurricane Matthew brought heavy rainfall to the eastern and central parts of the Carolinas (Weaver and others, 2016). Rainfall totals from 3 to more than 15 inches for the 3-day period October 7–9, 2016, were widespread. For that same period, one U.S. Geological Survey (USGS) raingage at the Cape Fear River at William O. Huske Lock near Tarheel in Bladen County, N.C., (USGS streamgage 02105500) recorded a total of about 16.9 inches of rain, and in South Carolina, 17.2 inches of rainfall was recorded near Dillon. For the Hurricane Matthew event, Weaver and others (2016) presented peak streamflow and (or) stage data for 139 streamgages (127 in North Carolina and 12 in South Carolina). Twenty-three of the 127 streamgages in North Carolina recorded stage only, thus leaving 104 streamgages in North Carolina for which both peak streamflow and stage were presented. Twenty-three of the 104 streamgages in North Carolina and 3 of the 12 streamgages in South Carolina had new peaks of record for streamflow associated with Hurricane Matthew. An additional 44 streamgages recorded new peaks that ranked in the top 5 for the period of record. Sixty-seven streamgages had record lengths of 30 or more years, and of those, 11 had new peaks of record, and 27 recorded peaks that ranked in the top 5 for the period of record. Historical flood records for USGS streamgage 02134500, Lumber River at Boardman, N.C., indicate that the October 2016 peak streamflow was the largest since 1901.

In October 2015, the presence of an upper atmospheric low-pressure system over the Southeast funneled tropical moisture from Hurricane Joaquin into South Carolina causing historic rainfall amounts (Feaster and others, 2015), which resulted in historic flooding in the central and coastal parts of the State. The USGS raingage at Black River at Kingstree, S.C. (USGS streamgage 02136000), recorded about 22.9 inches of rain for the period October 1–5, 2015. Over the same period, almost 27 inches of rain fell near Mount Pleasant in Charleston County, S.C. USGS streamgages recorded peaks of record at 17 locations, and 15 other streamgages had peaks ranking in the top 5 for the period of record. With respect to streamflow, USGS streamgage 02136000 recorded the largest peak streamflow in 87 years, which according to additional historic information was the largest peak since at least 1893, based on annual maximum peak stage records from the National Weather Service.

The USGS collects and disseminates streamflow data at more than 10,000 streamgages nationwide (fig. 4). Currently (October 2018) in North and South Carolina, the USGS operates 282 and 206 real-time streamgages, respectively, in cooperation with numerous local, State, and Federal agencies that monitor gage height, streamflow, reservoir elevations, and tidal streamflow (<https://waterdata.usgs.gov/usa/nwis/rt>, accessed September 20, 2018). Streamflow data collection serves a variety of purposes including providing information for flood forecasts and documenting flood extent and levels. Leading

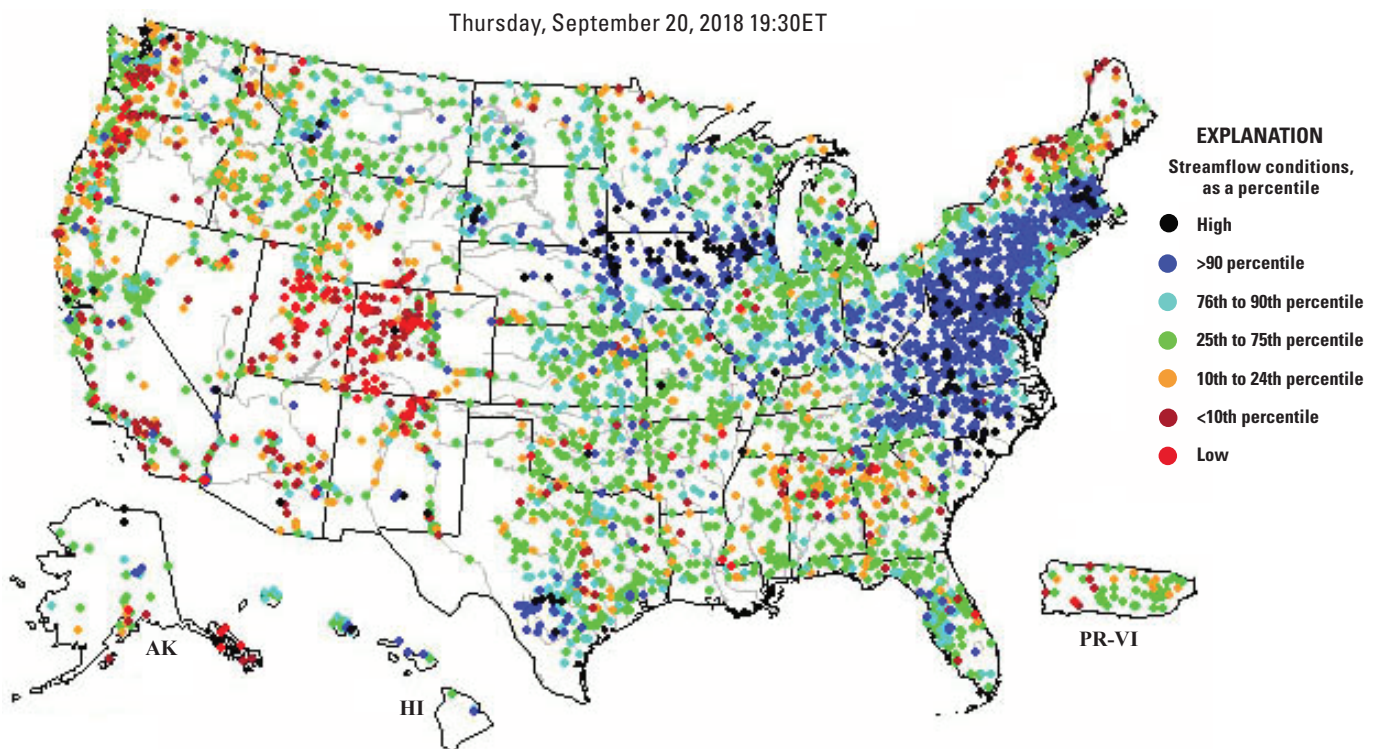

Figure 4. U.S. Geological Survey Real-Time Data Network for the United States (<https://waterdata.usgs.gov/usa/nwis/rt>, accessed September 20, 2018). Streamflow conditions are computed from the period of record for the current day of the year.

up to and during flooding, streamflow data are vital for flood warning, forecasting, and emergency management. The long-term systematic streamflow data are used to assess risk and to mitigate flooding through floodplain management and in the design or repair of infrastructure (for example, road, bridges, reservoirs, and pipelines), houses, and buildings.

Purpose and Scope

The purpose of this report is to provide preliminary data documenting the peak streamflows and stages for the rivers and streams in North and South Carolina that are part of the USGS Real-Time Data Network and were affected by catastrophic flooding following the passage of Hurricane Florence during September 13–17, 2018 (fig. 5). The 2018 flood peak streamflows are placed into context by ranking the September 2018 flood peaks with other annual flood peaks for the period of record at each streamgage having a minimum of 10 years of systematic record as well as historic floods that might precede USGS systematic records. National Weather Service (NWS) flood stage information is also provided at sites where a NWS flood stage has been defined (table 1 at the back of the report). As indicated by the modifier “preliminary,” both streamflow and rainfall data in this report are considered preliminary due to the possibility of modifications and adjustments as the data go through a formal review.

Study Area

The streamgage data (peak stage and streamflow) documented in this report are part of the USGS Real-Time Data Network for North Carolina and South Carolina, which have areas of 53,819 and 31,055 square miles, respectively. Both States are located on the South Atlantic slope adjacent to the Atlantic Ocean and are generally divided into three major physiographic provinces: Blue Ridge, Piedmont, and Coastal Plain (fig. 5; Cooke, 1936).

The Blue Ridge is a mountainous region of steep terrain with some stream gradients greater than 250 feet (ft) per mile (Bloxham, 1979). Land-surface elevations range from 1,000 to more than 3,500 ft above sea level in South Carolina and more than 6,000 ft above sea level in North Carolina. The Piedmont is characterized by rolling hills, elongated ridges, and moderately deep to shallow valleys. Piedmont land-surface elevations range from about 1,000 ft above sea level at the Blue Ridge foothills to about 300–400 ft above sea level at the Fall Line, which is the name given to the boundary between the Piedmont and Coastal Plain regions.

About two-thirds of South Carolina is in the Coastal Plain region, where bedrock is overlain by sediments that thicken from just a few feet near the Fall Line to about 3,800 ft near Hilton Head Island near the southernmost corner of the State (Badr and others, 2004). The Coastal Plain in North Carolina accounts for about one-third of the State’s total area and is overlain by a sedimentary wedge that thickens from a

featheredge at the Fall Line to more than 10,000 ft at Cape Hatteras at the Outer Banks (Giese and Mason, 1993; Winner and Coble, 1996). A narrow hilly region, known as the Sand Hills, is located at the Fall Line where the Piedmont descends to the Coastal Plain (Omernik, 1987). The transitional Sand Hills region is about 30 to 40 miles wide with elevations ranging from about 200 to more than 500 ft. The lower part of the Coastal Plain consists of low-elevation, flat plains with many swamps, marshes, dunes, barrier islands, and beaches, which typically are lower, flatter, and more poorly drained than the upper part of the Coastal Plain.

In both States, precipitation is principally delivered by storms that move inward from the Gulf of Mexico, the Caribbean Sea, and the Atlantic Ocean (U.S. Geological Survey, 1985). Additionally, local and upwind land surfaces, as well as lakes and reservoirs, provide moisture to the atmosphere by evaporation. In a normal year, monthly precipitation is highest in the winter, reaching a maximum in early March and then decreasing sharply in April and May. Fall is typically a dry season (except in instances when tropical storms or hurricanes occur) with minimal statewide precipitation during October and November.

Annual rainfall in South Carolina averages as much as 80 inches in the highest elevations of the Blue Ridge region to less than 45 inches in parts of the upper portion of the Coastal Plain and Sand Hills regions (Feaster and others, 2009). In general, the Blue Ridge region receives an average of about 56 inches or more of annual rainfall, the upper portion of the Piedmont about 47 to 55 inches, the lower portion of the Piedmont about 45 to 48 inches, the upper portion of the Coastal Plain about 44 to 49 inches, and the lower portion of the Coastal Plain about 46 to 53 inches.

In the Blue Ridge region of North Carolina, the annual average precipitation ranges from more than 90 inches in the southwestern part of the State (the rainiest region in the Eastern United States) to only 37 inches in the valley of the French Broad River, which is less than 50 miles to the north (State Climate Office of North Carolina, 2016). The average annual precipitation in the Piedmont region ranges from about 40 inches in the west to about 50 inches in the east near the Fall Line (State Climate Office of North Carolina, 2016). Average annual precipitation in the Coastal Plain region generally ranges from 50 to 55 inches, with higher values near 60 inches attributed to past tropical storms in the southern coastal region of North Carolina.

General Weather Conditions and Precipitation Causing the September 2018 Flooding

Hurricane Florence was the sixth named storm, third hurricane, and the first major hurricane of the 2018 Atlantic hurricane season (National Oceanic and Atmospheric

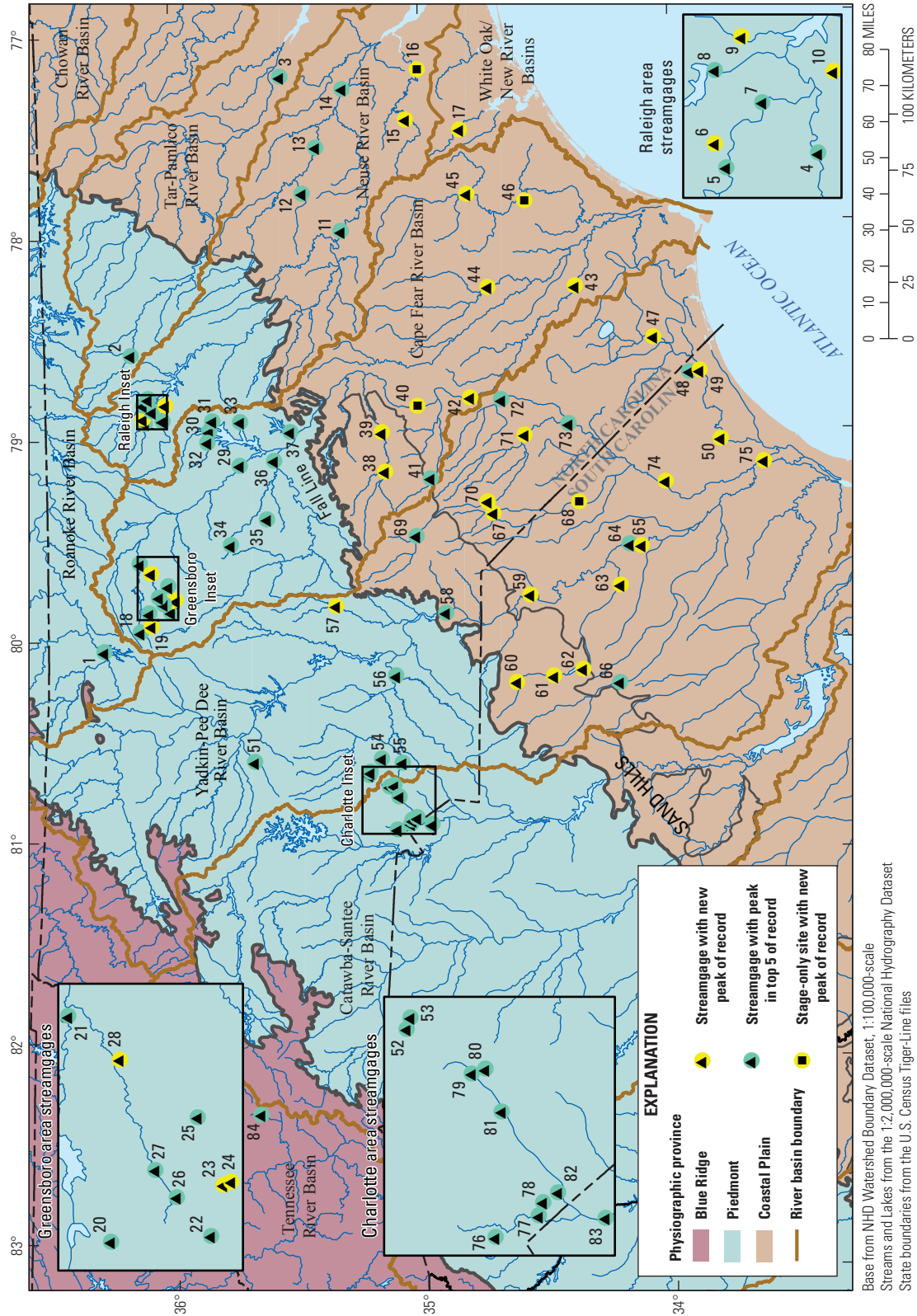

Base from NHD Watershed Boundary Dataset, 1:100,000-scale
Streams and Lakes from the 1:2,000,000-scale National Hydrography Dataset
State boundaries from the U.S. Census Tiger-Line files
Ecoregions from the U.S. Environmental Protection Agency 1:7,500,000-scale digital data (Omernik, 1987)

Figure 5. Selected U.S. Geological Survey real-time streamgages and major physiographic provinces in North and South Carolina.

Administration, 2018). Beginning as a strong tropical wave off the west coast of Africa on August 30, 2018, Florence became a tropical depression near Cape Verde on August 31 and began a west-northwest trek strengthening to a tropical storm by September 1 (fig. 2). Florence quickly gained strength and was a Category 4 hurricane by September 5, with maximum sustained winds of 130 miles per hour. After weakening to a tropical storm on September 7, a few days later the storm regained hurricane strength on September 9. Following a stint of rapid intensification on September 10, Florence again reached major hurricane status becoming a Category 3 and 4 hurricane on the same day with Category 4 winds of 140 miles per hour noted by the end of the day. Although Hurricane Florence's wind field continued to grow, increasing wind shear gradually weakened the storm, which led to the hurricane making landfall during the morning of September 14 at Wrightsville Beach, N.C., as a Category 1 hurricane (North Carolina Department of Public Safety, 2018).

As Florence moved inland, the forward motion slowed to about 2 to 3 miles per hour, producing large amounts of rain across the Carolinas (fig. 3) with the maximum 4-day total of about 36 inches in some areas of North Carolina and nearly 24 inches in some areas of South Carolina, resulting in historic flooding in many communities in both States. For the Hurricane Florence event, the NWS reported the highest total rainfall of 35.93 inches in Elizabethtown, N.C., and 27 additional locations with totals from 21.04 to 34.00 inches (National Weather Service, 2018b). Many of these locations set new State records for rainfall, exceeding the previous State record for rainfall from a tropical system of 24.06 inches that was set over a 4-day period in Southport, N.C., during Hurricane Floyd in 1999 (State Climate Office of North Carolina, 2018a). In South Carolina, the highest reported total rainfall of 23.63 inches was in Loris, S.C., and was the highest total rainfall in South Carolina from a tropical cyclone, replacing the previous total of 17.45 inches associated with Tropical Storm Beryl in 1994 (South Carolina State Climatology Office, 2018). An additional 17 locations in South Carolina reported rainfall totals between 10.10 and 22.58 inches. During the Hurricane Joaquin event in October 2015, a 4-day total rainfall of 26.88 inches was recorded in Mount Pleasant, South Carolina. However, because that total rainfall was a combination of the tropical storm and another front, it is not considered the largest rainfall event from a tropical storm (Melissa Griffin, South Carolina Department of Natural Resources, written commun., October 10, 2018).

Methods

In this report, streamflow data refer to both stage or gage height (in feet) and volumetric streamflow (in cubic feet per second). These data were collected systematically at USGS continuous record streamgages or from field measurements of stage in cases where the gage structure or equipment was damaged by flood waters. The peak-streamflow data used in the analyses in this report were obtained from the USGS National Water Information System (<https://waterdata.usgs.gov/nwis/sw>, accessed October 2, 2018).

U.S. Geological Survey streamgages operate autonomously by collecting data at regular time intervals (typically either 5 or 15 minutes) dependent on watershed size and how rapidly the water rises in the stream. Typical streamgage records include observations of stage. The stage data are collected using a variety of methods, including float, submersible pressure transducer, nonsubmersible pressure transducer, or noncontact radar. More information on how USGS streamgages operate is available in Lurry (2011). Although stage data are important, streamflow is often more important for such purposes as streamflow forecasting and flood warning, water-quality loading computations, flood-frequency analysis, and flood mitigation planning. Computation of streamflow at a streamgage requires periodic measurements of streamflow over a range of stage. The relation defined between stage and measured streamflow, or rating curve, is used to convert the stage data to streamflow. USGS personnel collect physical observations of stream velocity and stream depth onsite to determine near-instantaneous streamflow (fig. 6; Turnipseed and Sauer, 2010).

In most cases the relation is a simple stage-streamflow relation or rating curve. After constructing the rating curve, continued periodic measurements of streamflow are required at various stages to verify or support changes to a streamgage rating curve. During the September 2018 flood,



Figure 6. U.S. Geological Survey personnel use an acoustic Doppler current profiler to make a streamflow measurement of flood waters from the Cape Fear River in Kelly, North Carolina, on September 20, 2018.

8 Preliminary Peak Stage and Streamflow Data at USGS Streamgages in N.C. and S.C. Following Hurricane Florence

USGS personnel made 113 streamflow measurements at 61 locations in North Carolina and 55 measurements at 26 locations in South Carolina to verify, update, or extend existing stage-streamflow rating curves. An example rating curve and rating-curve extension is shown in figure 7. In addition, the USGS deployed 17 rapid deployment gages (RDGs) in North Carolina and 15 in South Carolina (fig. 8;

<https://stn.wim.usgs.gov/FEV/>, accessed October 12, 2018). USGS RDGs are fully functional streamgages designed to be deployed quickly and temporarily to measure and transmit stream stage data in emergency situations (<https://water.usgs.gov/floods/resources/rdg/>, accessed October 4, 2018).

In some cases, direct measurements of streamflow during a flood are not possible or are impractical because of safety

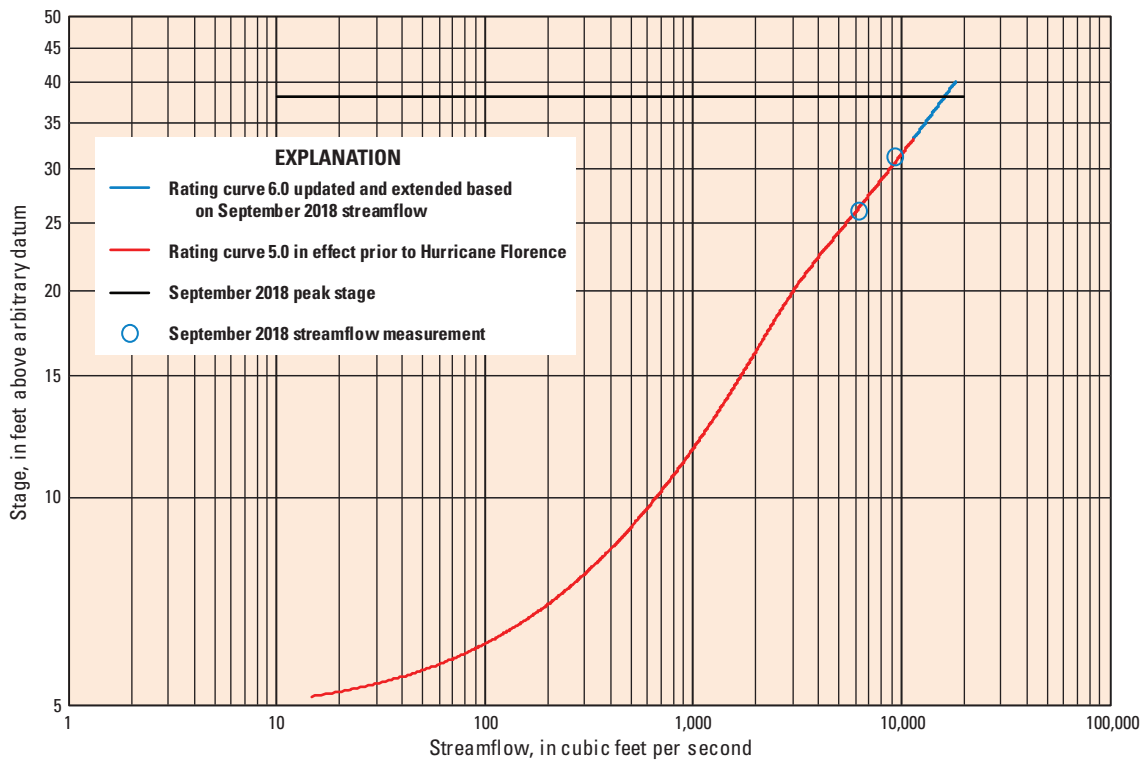

Figure 7. Rating curve developed for use before (red) and after (blue) the September 2018 flood for Little River at Manchester in northern Cumberland County, N.C. (USGS streamgage 02103000), showing streamflow measurements made during the event.



Figure 8. U.S. Geological Survey rapid deployment gage at Trent River at U.S. Highway 70 at New Bern, N.C., September 20, 2018.

concerns or inaccessibility to the measurement site. In those instances, indirect measurement methods can be used (Benson and Dalrymple, 1967), whereby water-surface profiles determined by high-water marks, channel roughness, and geometry are used in hydraulic equations based on the principles of conservation of energy, conservation of momentum, and continuity to compute the peak streamflow for that flood. The high-water marks and channel geometry are determined by field survey. Roughness typically is subjectively determined on the basis of bed material, cross-section irregularities, depth of streamflow, vegetation, and channel alignment. The USGS assigns uncertainty/accuracy estimates to each indirect measurement on the basis of the hydraulic and geometry conditions found at each field site (Benson and Dalrymple, 1967; Dalrymple and Benson, 1967; Hulsing, 1967; Matthai,

1967; Bodhaine, 1968). In other cases, high-water marks are documented for the purpose of recording the depth of the flood waters (fig. 9; Koenig and others, 2016; Feaster and Koenig, 2017).

Flood Exceedance Probabilities of Peak Streamflows

Immediately after a flood, emergency managers and water resources engineers commonly need to know the expected frequency and magnitude of peak streamflows observed during the event. Flood-frequency analyses for streamgages with sufficient record can provide insight into the occurrence or likelihood of peak streamflows of varying magnitudes. The annual exceedance probability (AEP) for a particular streamflow is the probability of that streamflow being equaled or exceeded in any given year. For example, an AEP of 0.01 means there is a 1 percent (AEP×100) chance of that streamflow magnitude being equaled or exceeded in any given year. Stated another way, the odds are 1 in 100 that the indicated streamflow will be equaled or exceeded in any given year. The traditional concept of recurrence interval is directly related to the AEP. By definition, the recurrence interval (in years) is equal to one divided by the AEP. For example, the AEP of 0.01 (or 1 percent) corresponds to the 100-year flood.

The “100-year flood” is an estimate of the long-term average and does not imply that a flood only occurs every 100 years (Holmes and Dinicola, 2010). For example, if there were a streamgage that had 1,000 years of annual peak streamflow data, it could be expected that 10 floods in that 1,000-year record would have a flood magnitude equal to or greater than the “100-year flood;” however, those 10 floods would not occur at equal 100-year intervals. In one part of the 1,000-year record, there might be 15 years or less between two “100-year floods,” whereas in another part of the record, there might be 150 or more years between “100-year floods.”

Table 2 lists the recurrence intervals for commonly used flood exceedance probabilities and the associated AEP, in percent. In a typical flood-frequency analysis for a



Figure 9. U.S. Geological Survey field crews conducting surveys of high-water marks to document the depth of flood waters near Northeast Creek in Piney Green in Onslow County, N.C., for the September 2018 flood.

Table 2. Selected recurrence intervals and the associated annual exceedance probabilities.

Recurrence interval (years)	Annual exceedance probability (percent)
2	50
5	20
10	10
25	4
50	2
100	1
200	0.5
500	0.2

USGS streamgage, results are only reported up to an AEP of 0.2 percent (or 1 in 500 chance, also referred to as a 500-year recurrence interval) because the record lengths of most USGS peak-streamflow files are less than 100 years (Feaster and others, 2009). Consequently, extrapolating beyond a 0.2-percent AEP streamflow is not warranted due to the large uncertainty.

The flood-frequency estimates for this report were made using the Expected Moments Algorithm (EMA) (Cohn and others, 1997, 2001) in the USGS software package PeakFQ, version 7.1 (Flynn and others, 2006; Veilleux and others, 2014) (fig. 10). The Advisory Committee on Water Information, Subcommittee on Hydrology, Hydrologic Frequency Analysis Work Group (<https://acwi.gov/hydrology/Frequency/>, accessed October 12, 2018) provided standard methods for computing peak-streamflow frequency in a recently (2018) published document referred to as Bulletin 17C (England and others, 2018). Bulletin 17C is an update to Bulletin 17B (Interagency Advisory Committee on Water Data, 1982). Flood computation equations and algorithms in Bulletin 17C have been implemented into the PeakFQ program. The September 2018 peak streamflows were included in the PeakFQ analyses per guidance provided in USGS Office of Surface Water Technical Memorandum 2013.01 (U.S. Geological Survey, 2012).

Peak Streamflows and Stages

Peak streamflow and stage during the September 2018 flood are listed for 84 streamgage locations in table 1 (at the back of the report), and their site locations are shown in figure 5. The streamgages included in table 1 were chosen because (1) peak stage and (or) peak streamflow for the September 2018 flood event were monitored at the site, (2) the streamgage had at least 10 years of reviewed and approved annual maximum peak streamflows available through water year 2017, and (3) the Hurricane Florence peak ranked in the top 5 for the period of record. Four of the 84 streamgages were stage-only gages that had at least 10 years of record and for which the September 2018 peak stage was the peak of record. Rank comparisons were made on peak streamflow only. It is possible that the peak stage for this event at some sites may be lower than a previous peak stage due to backwater conditions, datum changes, or changes in the upper end of the rating curve.

The ranks for the September 2018 streamflow peak at selected streamgages for the period of record are presented in table 1. Twenty-eight of the 80 streamgages measuring streamflow had new peaks of record. Of the 43 streamgages

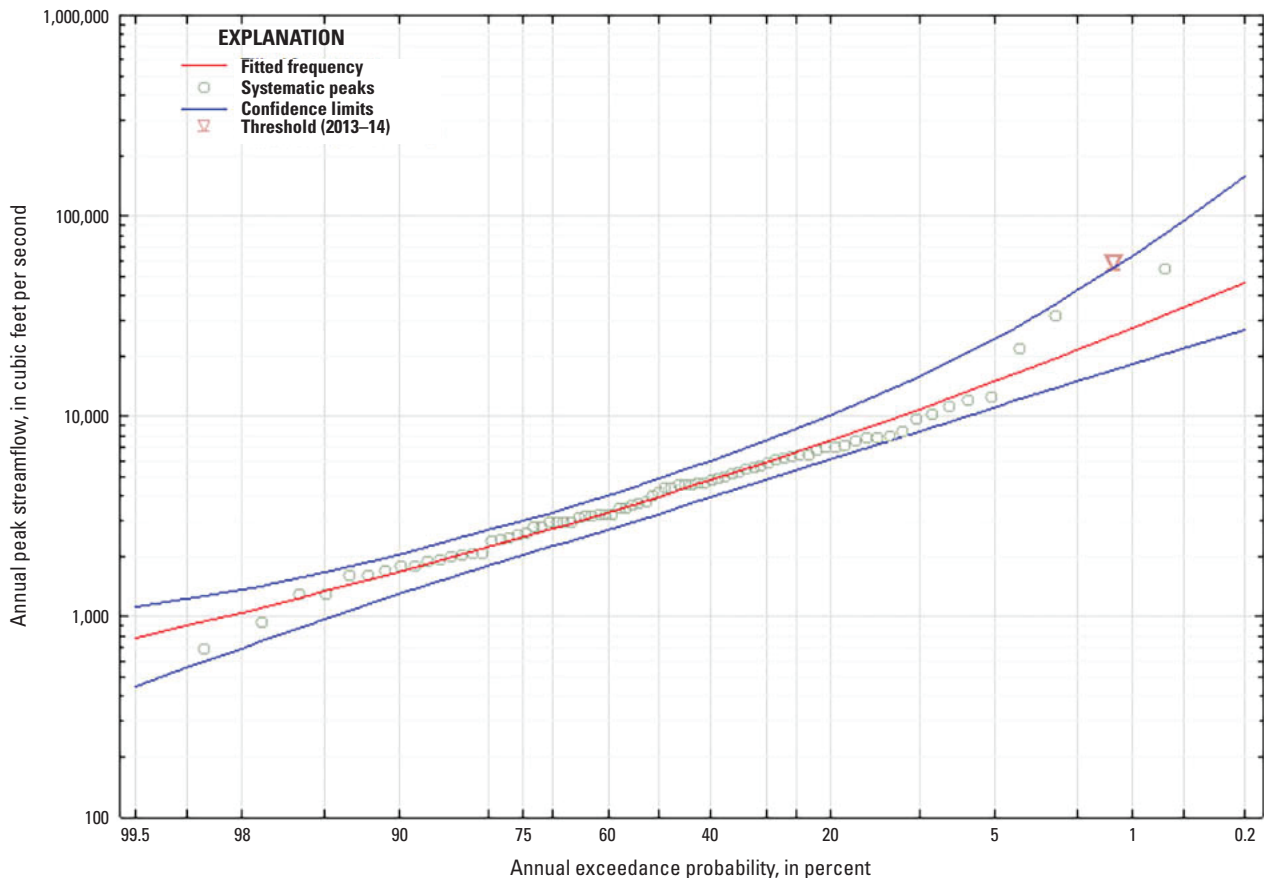

Figure 10. Flood-frequency curve for the annual peak streamflows at U.S. Geological Survey streamgage 02109500, Waccamaw River at Freeland, N.C.

with long-term records¹ of 30 or more years, 14 had new peaks of record: 02108000, Northeast Cape Fear River near Chinquapin, N.C. (78 years) (fig. 10); 02109500, Waccamaw River at Freeland, N.C. (77 years); 02135000, Little Pee Dee River at Galivants Ferry, S.C. (77 years); 02105500, Cape Fear River at William O Huske Lock near Tarheel, N.C. (71 years); 02106500, Black River near Tomahawk, N.C. (70 years); 02110500, Waccamaw River near Longs, S.C. (68 years); 02092500, Trent River near Trenton, N.C. (67 years); 02128000, Little River near Star, N.C. (64 years); 02130900, Black Creek near McBee, S.C. (59 years); 02130910, Black Creek near Hartsville, S.C. (58 years); 02102908, Flat Creek near Inverness, N.C. (50 years); 02105769, Cape Fear at Lock #1 near Kelly, N.C. (49 years); 02132320, Big Shoe Heel Creek near Laurinburg, N.C. (31 years); and 02133624, Lumber River near Maxton, N.C. (30 years).

In addition to the 28 streamgages that had new peaks of record for streamflow, 49 streamgages recorded new peak streamflows that ranked in the top 5 for the period of record. For streamgages with at least 30 years of record, 20 recorded peak streamflows ranking in the top 5 for the period of record. For 11 of the 28 streamgages for which the September 2018 peak streamflow was the peak of record, the October 2016 peak following Hurricane Matthew was the second largest peak of record, and for another five the September 1999 peak following Hurricane Floyd was the second largest peak of record (table 1; Weaver and others, 2016). For streamgage 02130980, Black Creek near Quinby, S.C., the second largest peak of record was recorded in October 2015 following Hurricane Joaquin (Feaster and others, 2015).

Peak streamflow data following Hurricane Florence were not available for three streamgages prior to the publication of this report. Of those three streamgages, two recorded a new peak stage of record (streamgages 02086624, Knap of Reeds Creek near Butner, N.C., and 02093000, New River near Gum Branch, N.C.) and one recorded the second highest peak stage of record (02101800, Tick Creek near Mount Vernon Springs, N.C.).

Estimated Magnitudes and Flood Exceedance Probabilities of Peak Streamflows

Updated at-site flood-frequency streamflows for selected AEPs (50, 20, 10, 4, 2, 1, 0.5, and 0.2 percent) were computed for USGS streamgages that had at least 10 years of approved annual maximum peak streamflows through the 2017

water year² and for which the peak streamflow associated with Hurricane Florence exceeded the peak of record of the approved peak streamflows (table 3). For unregulated streamgages, the expected peak streamflows for selected AEPs and their 95-percent confidence intervals were computed by weighting the updated flood-frequency analysis at each streamgage, including the September 2018 peak streamflow from Hurricane Florence, with the regional regression estimate for the same location using equations from Feaster and others (2009) and Weaver and others (2009). For urban streamgages, the at-site flood-frequency streamflows were weighted with the regression equation estimates from Feaster and others (2014). The weighting was computed using the variance of the two estimates as outlined in Bulletin 17C (England and others, 2018). Such weighting can reduce the uncertainty in the peak-streamflow statistics with the weights being based on the variance of the EMA estimate and the variance of the regional regression equations (England and others, 2018). The weighted streamflow estimates were then used to determine the AEP associated with the September 2018 peak streamflow. No weighted values were computed for the at-site flood-frequency streamflows estimated for regulated streamgages.

In addition to weighting the updated at-site streamflows for selected AEPs with the appropriate regional regression equations, weighted upper and lower 95-percent confidence interval streamflows for the selected AEPs also were computed using methods described in USGS Office of Surface Water Information and Technical Note 2014.43 (table 3; U.S. Geological Survey, 2014b). The regional regression equations, regression equation estimates at USGS streamgages, and variances are documented in Feaster and others (2009, 2014) and Weaver and others (2009).

Table 4 lists the peak gage-height data, peak streamflow data, and the corresponding AEP (in percent) determined for the September 2018 flood for the 28 USGS streamgages that measured record annual peak streamflow in North and South Carolina and had at least 10 years of approved annual maximum peak streamflows through the 2017 water year. The data listed in tables 3 and 4 are currently (October 2018) considered provisional until final verification of the peak-streamflow data. The estimated AEP for the September 2018 flood for each streamgage was determined using log-linear interpolation of the weighted streamflow estimates included in table 3, following equation 1 in USGS Office of Surface Water Technical Memorandum 2013.01 (U.S. Geological Survey, 2012) based on the weighted flood-frequency estimates (table 3). The uncertainty in the estimated AEP can increase when a specific AEP is assigned to an observed flood event such as the September 2018 flood. Techniques recommended by U.S. Geological Survey (2012) also were used to estimate a 90-percent confidence interval that is likely to include the true AEP.

¹The USGS uses a 30-year criterion to identify those streamgages having long-term periods of streamflow record (U.S. Geological Survey, 2014a).

²The water year is the annual period from October 1 through September 30 and is designated by the year in which the period ends.

Table 3. Site identification number, station number, and weighted (unregulated sites only) estimated peak streamflows for selected annual exceedance probabilities with 95-percent confidence intervals at selected U.S. Geological Survey streamgages in North Carolina and South Carolina.

[ft³/s, cubic feet per second; USGS, U.S. Geological Survey; AEP, annual exceedance probability]

Site identification number (fig. 5)	USGS station number	Number of annual peaks	Historical period of record (years)	Estimated peak streamflows for selected AEP								
				50-percent chance AEP		20-percent chance AEP		95-percent chance AEP				
				Estimate	95-percent confidence interval	Estimate	95-percent confidence interval	Estimate	95-percent confidence interval			
6	0208524090	24	none	726	522	1,010	1,460	1,030	2,070	2,050	1,390	3,020
10	02086849	23	91	2,080	1,870	2,320	2,610	2,320	2,930	2,940	2,560	3,380
15	02092500	67	none	1,980	1,630	2,410	3,990	3,160	5,040	5,810	4,390	7,690
19	02093877	14	none	471	400	555	646	529	789	792	627	1,000
23	02094770	20	none	1,760	1,510	2,050	2,370	1,990	2,820	2,800	2,290	3,420
24	02094775	20	none	642	542	760	884	744	1,050	1,050	864	1,280
28	0209553650	20	none	4,750	4,220	5,340	6,030	5,180	7,020	7,000	5,830	8,400
38	02102908	50	none	125	101	154	236	185	301	331	249	439
39	02103000	28	none	3,000	2,360	3,820	5,160	3,940	6,750	6,790	5,000	9,220
42	02105500 ^a	38	none	28,800	24,300	34,200	41,300	34,700	51,900	50,200	41,500	69,400
43	02105769 ^a	38	none	24,700	20,500	29,700	36,400	29,900	48,300	45,600	36,700	70,400
44	02106500	67	91	4,390	3,670	5,250	8,310	6,770	10,200	11,800	9,240	15,100
45	02108000	78	111	5,150	4,480	5,920	8,820	7,450	10,400	11,900	9,770	14,500
47	02109500	77	none	3,950	3,340	4,680	7,480	6,140	9,110	10,600	8,350	13,500
49	02110500	68	none	5,660	4,780	6,700	10,400	8,540	12,700	14,400	11,400	18,200
50	02110704	24	none	6,890	5,200	9,140	13,000	9,380	18,000	18,000	12,400	26,200
57	02128000	64	74	4,320	3,730	5,000	7,050	5,960	8,350	9,170	7,530	11,200
59	02130561 ^a	27	none	56,200	42,900	73,300	87,600	67,700	119,000	109,000	84,200	167,000
60	02130840	13	none	595	409	866	1,090	722	1,650	1,470	933	2,320
61	02130900	59	none	746	637	874	1,270	1,060	1,530	1,700	1,360	2,120
62	02130910 ^a	58	none	712	576	900	1,220	1,000	1,700	1,710	1,310	2,840
63	02130980 ^a	17	none	1,680	1,040	2,970	3,350	1,940	9,070	5,120	2,900	24,500
65	02131010 ^a	23	none	30,500	21,900	44,500	52,300	35,700	101,000	73,300	48,900	206,000
67	02132320	31	none	564	443	718	1,080	809	1,440	1,540	1,100	2,150
70	02133624	30	none	1,920	1,530	2,410	3,410	2,600	4,470	4,670	3,400	6,420
71	02134170	18	none	3,330	2,410	4,600	6,330	4,400	9,110	8,850	5,880	13,300
74	02135000	77	91	11,500	10,000	13,200	19,000	16,300	22,100	24,700	20,700	29,400
75	02135200 ^a	15	none	41,900	27,100	66,300	73,900	46,700	155,000	102,000	63,900	324,000

Table 3. Site identification number, station number, and weighted (unregulated sites only) estimated peak streamflows for selected annual exceedance probabilities with 95-percent confidence intervals at selected U.S. Geological Survey streamgages in North Carolina and South Carolina.—Continued

[ft³/s, cubic feet per second; USGS, U.S. Geological Survey; AEP, annual exceedance probability]

Site identi- fication number (fig. 5)	USGS station number	Number of annual peaks	Historical period of record (years)	Estimated peak streamflows for selected AEP with 95-percent confidence intervals (ft ³ /s)								
				4-percent chance AEP		2-percent chance AEP		1-percent chance AEP				
				Estimate	95 percent confidence interval	Estimate	95 percent confidence interval	Estimate	95 percent confidence interval			
			Lower	Upper		Lower	Upper		Lower	Upper		
6	0208524090	24	none	2,830	1,810	4,420	3,480	2,130	5,700	4,100	2,390	7,040
10	02086849	23	91	3,350	2,850	3,940	3,650	3,040	4,380	3,930	3,200	4,830
15	02092500	67	none	8,580	6,040	12,200	11,000	7,330	16,500	13,600	8,560	21,600
19	02093877	14	none	1,020	761	1,370	1,240	881	1,740	1,460	987	2,160
23	02094770	20	none	3,380	2,640	4,330	3,830	2,870	5,110	4,280	3,080	5,960
24	02094775	20	none	1,280	1,010	1,630	1,460	1,110	1,930	1,640	1,190	2,250
28	0209553650	20	none	8,380	6,560	10,700	9,550	7,100	12,900	10,800	7,590	15,400
38	02102908	50	none	471	332	668	585	392	873	704	448	1,110
39	02103000	28	none	8,990	6,250	12,900	10,700	7,100	16,100	12,400	7,860	19,600
42	02105500 ^a	38	none	62,000	49,800	105,000	71,300	55,600	146,000	81,000	61,000	193,000
43	02105769 ^a	38	none	59,200	45,500	131,000	70,800	52,200	189,000	83,700	59,000	272,000
44	02106500	67	91	17,100	12,600	23,200	21,900	15,400	31,200	27,100	18,000	40,700
45	02108000	78	111	16,300	12,700	20,900	20,100	14,900	27,000	24,300	17,300	34,200
47	02109500	77	none	15,500	11,500	20,900	19,700	13,800	28,100	24,500	16,300	36,800
49	02110500	68	none	20,300	15,200	27,200	25,400	18,100	35,700	31,000	21,000	45,700
50	02110704	24	none	25,200	16,200	39,100	31,300	19,200	51,100	37,800	22,000	65,000
57	02128000	64	74	12,200	9,530	15,600	14,600	10,900	19,500	17,200	12,400	23,900
59	02130561 ^a	27	none	137,000	104,000	259,000	158,000	115,000	344,000	178,000	124,000	447,000
60	02130840	13	none	1,970	1,180	3,300	2,360	1,340	4,140	2,750	1,500	5,060
61	02130900	59	none	2,330	1,770	3,070	2,860	2,070	3,940	3,440	2,380	4,970
62	02130910 ^a	58	none	2,560	1,810	6,460	3,400	2,230	12,500	4,470	2,700	22,400
63	02130980 ^a	17	none	8,480	4,320	74,800	12,100	5,500	175,000	17,000	6,810	421,000
65	02131010 ^a	23	none	110,000	66,800	526,000	146,000	81,000	1,030,000	192,000	96,200	2,060,000
67	02132320	31	none	2,270	1,510	3,410	2,920	1,850	4,620	3,630	2,180	6,050
70	02133624	30	none	6,530	4,450	9,580	8,070	5,230	12,500	9,690	5,960	15,800
71	02134170	18	none	12,400	7,730	19,900	15,400	9,140	25,900	18,600	10,500	32,900
74	02135000	77	91	32,500	26,100	40,500	38,900	30,100	50,300	45,500	33,800	61,200
75	02135200 ^a	15	none	149,000	87,600	817,000	191,000	106,000	1,460,000	242,000	126,000	2,610,000

Table 3. Site identification number, station number, and weighted (unregulated sites only) estimated peak streamflows for selected annual exceedance probabilities with 95-percent confidence intervals at selected U.S. Geological Survey streamgages in North Carolina and South Carolina.—Continued

[ft³/s, cubic feet per second; USGS, U.S. Geological Survey; AEP, annual exceedance probability]

Site identification number (fig. 5)	USGS station number	Number of annual peaks	Historical period of record (years)	Estimated peak streamflows for selected AEP with 95-percent confidence intervals (ft ³ /s)					
				0.5-percent chance AEP		0.2-percent chance AEP		95 percent confidence interval	
				Estimate	Lower	Upper	Estimate	Lower	Upper
6	0208524090	24	none	4,730	2,620	8,530	5,640	2,940	10,800
10	02086849	23	91	4,220	3,360	5,310	4,610	3,540	6,000
15	02092500	67	none	16,400	9,770	27,500	20,400	11,300	36,800
19	02093877	14	none	1,720	1,110	2,670	2,090	1,270	3,450
23	02094770	20	none	4,730	3,260	6,870	5,340	3,480	8,200
24	02094775	20	none	1,830	1,280	2,620	2,080	1,380	3,140
28	020953650	20	none	12,000	7,990	18,000	13,800	8,580	22,200
38	02102908	50	none	835	504	1,380	1,010	570	1,790
39	02103000	28	none	14,200	8,580	23,500	16,600	9,430	29,200
42	02105500 ^a	38	none	91,100	66,100	248,000	105,000	72,500	346,000
43	02105769 ^a	38	none	98,200	65,900	391,000	120,000	75,400	633,000
44	02106500	67	91	32,700	20,600	51,800	40,900	24,100	69,400
45	02108000	78	111	28,800	19,500	42,500	35,400	22,600	55,500
47	02109500	77	none	29,500	18,700	46,600	37,000	21,900	62,600
49	02110500	68	none	36,900	23,900	57,100	45,600	27,700	75,200
50	02110704	24	none	44,300	24,500	80,000	53,700	27,800	104,000
57	02128000	64	74	19,900	13,700	29,000	23,700	15,400	36,600
59	02130561 ^a	27	none	199,000	131,000	577,000	227,000	138,000	805,000
60	02130840	13	none	3,190	1,660	6,140	3,720	1,820	7,620
61	02130900	59	none	4,070	2,690	6,170	4,950	3,070	7,980
62	02130910 ^a	58	none	5,820	3,230	40,500	8,150	4,020	89,200
63	02130980 ^a	17	none	23,600	8,260	1,040,000	35,900	10,400	3,510,000
65	02131010 ^a	23	none	250,000	113,000	4,210,000	352,000	136,000	11,000,000
67	02132320	31	none	4,410	2,510	7,730	5,540	2,950	10,400
70	02133624	30	none	11,500	6,720	19,700	13,900	7,610	25,400
71	02134170	18	none	21,800	11,700	40,500	26,400	13,300	52,200
74	02135000	77	91	52,500	37,500	73,600	62,300	42,100	92,100
75	02135200 ^a	15	none	303,000	146,000	4,710,000	402,000	174,000	10,400,000

^aStation is regulated and, therefore, the estimated peak flows and confidence intervals were not weighted but represent the at-site flood-frequency analysis.

Table 4. Peak gage heights, peak streamflows, and estimated annual exceedance probabilities for the September 2018 Hurricane Florence related-flood event at selected U.S. Geological Survey streamgages in North and South Carolina.

[USGS, U.S. Geological Survey; ft, feet; ft³/s, cubic feet per second; AEP, annual exceedance probability; <, less than]

Site identification number (fig. 5)	USGS station number	USGS station name	Peak streamflow for September 2018 flood					AEP for observed September 2018 flood ^a		
			Date of peak streamflow	Peak gage height (ft)	Peak stream-flow (ft ³ /s)	Rank of peak stream-flow in record	Number of annual peaks	Estimate	Lower	Upper
6	0208524090	Mountain Creek at SR1617 near Bahama, NC	9/17/2018	12.92	3,370	1	24	^b 2.3	0.2	11.7
10	02086849	Ellerbe Creek near Gorman, NC	9/17/2018	12.96	3,140	1	23	^b 7.1	0.2	12.2
15	02092500	Trent River near Trenton, NC	9/16/2018	24.23	67,700	1	67	^b <0.2	<0.2	4.4
19	02093877	Brush Creek at Muirfield Road at Greensboro, NC	9/17/2018	11.10	907	1	14	^b 6.8	0.4	19.3
23	02094770	South Buffalo Creek at US 220 at Greensboro, NC	9/17/2018	16.77	3,340	1	20	^b 4.4	0.3	13.9
24	02094775	Ryan Creek below US 220 at Greensboro, NC	9/17/2018	11.78	1,180	1	20	^b 6.5	0.3	13.9
28	0209553650	Buffalo Creek at SR2819 near McLeansville, NC	9/17/2018	21.45	9,450	1	20	^b 2.2	0.3	13.9
38	02102908	Flat Creek near Inverness, NC	9/17/2018	9.36	826	1	50	^b 0.5	<0.2	5.8
39	02103000	Little River at Manchester, NC	9/18/2018	38.30	16200	1	28	^b 0.2	0.2	10.1
42	02105500	Cape Fear River at Wilm O. Huske Lock near Tarheel, NC	9/19/2018	38.66	87,400	1	38	0.7	<0.2	7.6
43	02105769	Cape Fear River at Lock #1 near Kelly, NC	9/21/2018	30.68	76,700	1	38	1.5	<0.2	7.6
44	02106500	Black River near Tomahawk, NC	9/18/2018	31.34	54700	1	67	^b <0.2	<0.2	4.4
45	02108000	Northeast Cape Fear River near Chincquapin, NC	9/17/2018	25.77	41300	1	78	^b <0.2	<0.2	3.8
47	02109500	Waccamaw River at Freeland, NC	9/19/2018	22.61	53600	1	77	^b <0.2	<0.2	3.8
49	02110500	Waccamaw River near Longs, SC	9/20/2018	20.22	57,500	1	68	^d <0.2	<0.2	4.3
50	02110704	Waccamaw River at Conway Marina at Conway, SC	9/26/2018	21.16	49,000	1	24	^b 0.3	0.2	11.7
57	02128000	Little River near Star, NC	9/17/2018	28.80	33000	1	64	^b <0.2	<0.2	4.6
59	02130561	Pee Dee River near Bennettsville, SC	9/18/2018	94.25	226,000	1	27	0.7	0.2	10.5
60	02130840	Black Creek below Chesterfield, SC	9/17/2018	11.99	3,690	1	13	^b 0.2	0.4	20.6
61	02130900	Black Creek near McBee, SC	9/17/2018	13.39	4,940	1	59	^b 0.2	<0.2	5.0
62	02130910	Black Creek near Hartsville, SC	9/17/2018	13.47	5,270	1	58	0.7	<0.2	5.0
63	02130980	Black Creek near Quinby, SC	9/17/2018	17.37	6,880	1	17	6.5	0.3	16.2
65	02131010	Pee Dee River below Pee Dee, SC	9/21/2018	36.96	139,000	1	23	2.3	0.2	12.2
67	02132320	Big Shoe Heel Creek near Laurinburg, NC	9/17/2018	9.49	6,090	1	31	^b <0.2	0.2	9.2
70	02133624	Lumber River near Maxton, NC	9/19/2018	20.61	22,200	1	30	^b <0.2	0.2	9.5
71	02134170	Lumber River at Lumberton, NC	9/17/2018	22.21	15,600	1	18	^b 0.9	0.3	15.3
74	02135000	Little Pee Dee River at Galivants Ferry, SC	9/21/2018	17.21	66,900	1	77	^d <0.2	<0.2	3.8
75	02135200	Pee Dee River at Hwy 701 Near Bucksport, SC	9/26/2018	25.00	136,000	1	15	5.4	0.3	18.1

^aDetermined using methods in U.S. Geological Survey Office of Surface Water Technical Memorandum 2013.01.

^bDetermined using AEP estimates that were computed using PeakFQ and weighted with regional regression equation estimates from Weaver and others (2009).

^cDetermined using AEP estimates that were computed using PeakFQ and weighted with regional regression equation estimates from Feaster and others (2014).

^dDetermined using AEP estimates that were computed using PeakFQ and weighted with regional regression equation estimates from Feaster and others (2009).

Of the 28 streamgages analyzed, the estimated AEP for the Hurricane Florence peak streamflow at nine of the streamgages was less than 0.2 percent, which in terms of recurrence intervals is greater than a 500-year flood event, at three streamgages it was equal to a 0.2-percent flood event (500-year recurrence interval), and at six streamgages it was between a 0.2- and 1-percent AEP flood (between a 500- and 100-year recurrence interval, respectively). For the remaining 10 streamgages, the estimated AEP was between 1.5 and 7.1 percent, which in terms of recurrence intervals is approximately a 67- to 14-year flood event, respectively.

Comparison to Past Floods

In the Pee Dee River Basin, a new peak of record occurred on September 21, 2018, for streamgage 02135000, Little Pee Dee River at Galivants Ferry, which, for the South Carolina sites having a new period of record because of Hurricane Florence, has the longest period of record going back to 1942 (fig. 11). Also, based on a historic floodmark of 16.0 ft recorded by a local resident, the Hurricane Florence flood is likely the largest flood since 1928, with a stage of 17.21 ft and corresponding streamflow of 66,900 cubic feet per second (ft³/s). The second largest peak of record occurred less than 2 years ago on October 12, 2016, as a result of Hurricane Matthew, with a peak streamflow of 59,300 ft³/s and a peak stage of 17.1 ft.

In the Waccamaw River Basin, annual peak stage and streamflow data have been collected at streamgage 02109500, Waccamaw River at Freeland, N.C., since 1940 (fig. 12). For Hurricane Florence, the peak occurred on September 19, 2018, at a magnitude of 53,600 ft³/s and a stage of 22.61 ft, becoming the new peak of record for the 77 years of available record. The second largest peak occurred on September 21, 1999, at a magnitude of 31,200 ft³/s and a stage of 19.3 ft, and was associated with rainfall from Hurricane Floyd. The third largest peak occurred on October 12, 2016, at a magnitude of 21,700 ft³/s and a stage of 17.07 ft, and was associated with rainfall from Hurricane Matthew.

Although it is rare to have two historic floods recorded at a location in such a short timeframe as occurred at streamgage 02135000 and several other sites listed in table 1, it is not unprecedented. At streamgage 02169500, Congaree River at Columbia, S.C., the peak of record since at least 1892 occurred on August 27, 1908. The second and third largest floods, however, occurred in consecutive years on August 18, 1928, and October 3, 1929, respectively (fig. 13). Both flood events were related to tropical storm systems (Frankenfield, 1928; Spencer, 1929).

Streamgage 02169500 has one of the longest records of annual peak streamflows of the USGS streamgages in South Carolina, with systematic records of annual peak streamflow from 1892 to the present and additional stage information for a flood in 1852 (fig. 13). The Congaree River is formed by the convergence of the Saluda and Broad Rivers at Columbia, S.C. The Saluda River is regulated by the Saluda

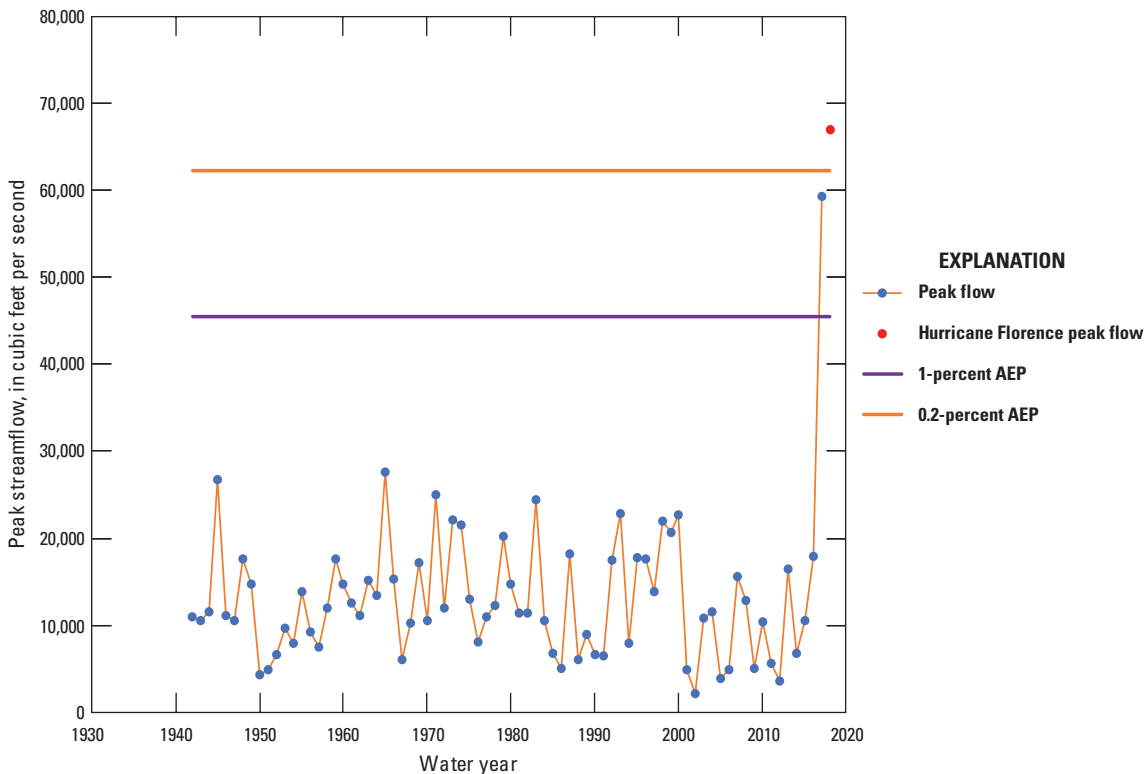

Figure 11. Peak streamflows for the period of record and the peak streamflow from Hurricane Florence at U.S. Geological Survey streamgage 02135000, Little Pee Dee River at Galivants Ferry, S.C.

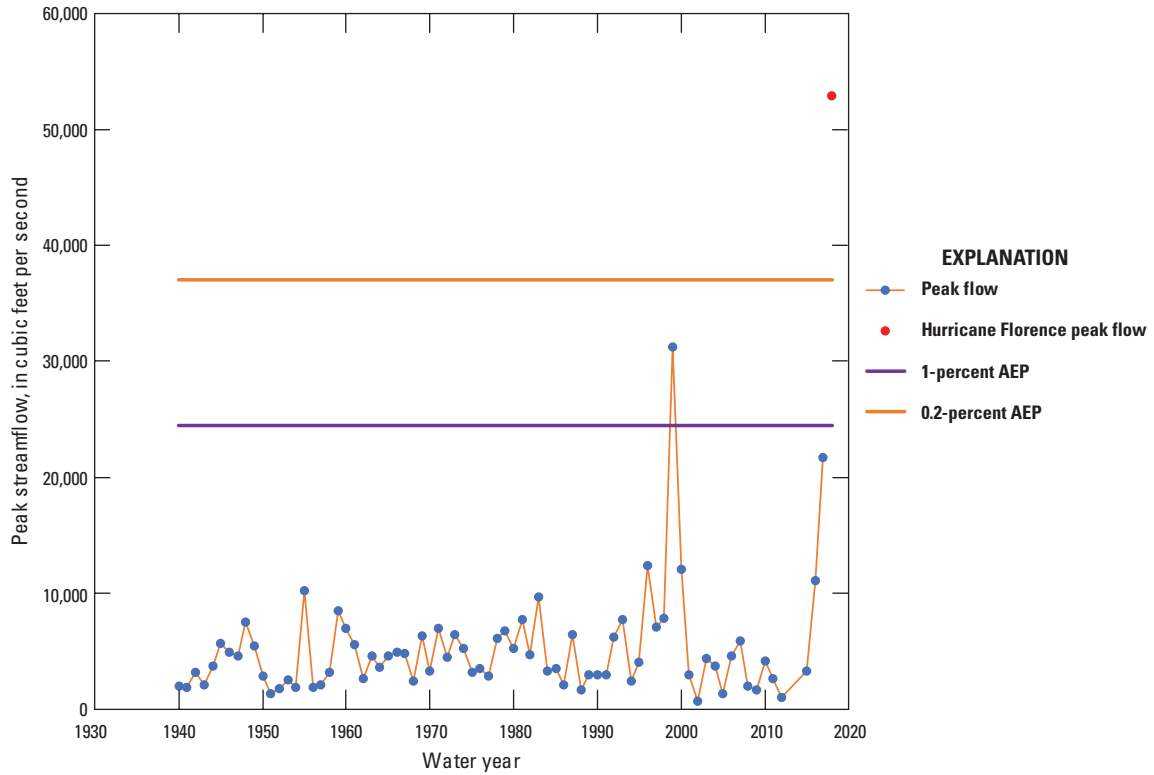

Figure 12. Peak streamflows for the period of record and the peak streamflow from Hurricane Florence at U.S. Geological Survey streamgage 02109500, Waccamaw River at Freeland, N.C.

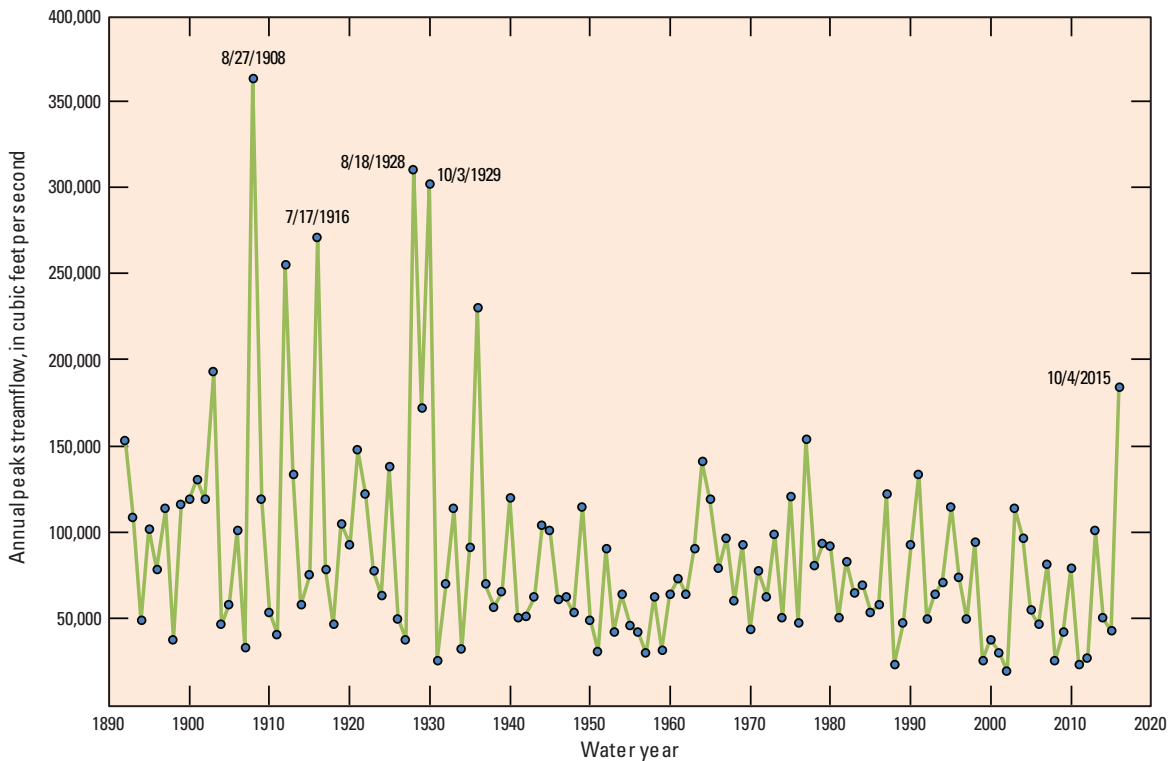

Figure 13. Annual peak flows at U.S. Geological Survey streamgage 02169500, Congaree River at Columbia, S.C. [Drainage area is 7,850 square miles.]

Dam, which was completed in 1929 (Conrads and others, 2008). Low-head dams on the Broad River have regulated low streamflows since the late 1880s and early 1900s, but flood streamflows are essentially unregulated. The Broad River Basin accounts for approximately two-thirds of the drainage area for the Congaree River at the Columbia streamgage.

Conrads and others (2008) did a historical analysis to assess the effects the Saluda Dam has had on the flood frequency of Congaree River streamflows and concluded the 1-percent chance flood (also referred to as the 100-year flood) is likely reduced by about 18 percent due to regulation on the Saluda River. Under extreme flood conditions, emergency spillway gates at the Saluda Dam are used to prevent overtopping of the dam. During the historic flood of 1929, the spillway gates were opened on October 1, 1929, and held open through the afternoon of October 6 (South Carolina Electric and Gas, written commun., May 18, 2017). The spillway gates also were opened during the October 2015 flood event related to Hurricane Joaquin (SCE&G, 2018). Consequently, for major floods, operations at the Saluda Dam are likely to be such that the inflow to the reservoir is passed through the system and, thus, the resulting peak streamflows on the Congaree River will tend to reflect preregulation conditions.

Another example of two major flood events occurring within a short period of time happened on the Savannah River prior to regulation. Streamgage 02197000, Savannah River at Augusta, Georgia (fig. 14), has one of the longest continuous records of peak streamflows going back to 1876, as well as five additional peak streamflows going back to 1796. Thus, the peak of record in the preregulation period prior to construction of the J. Strom Thurmond Dam in the early 1950s likely represents the largest flood on the Savannah River since at least 1796. As shown in figure 14, regulation had a substantial effect on reducing the peak streamflows at this site. As indicated, the largest peak of record occurred on October 2, 1929, and the second largest peak occurred just 5 days earlier on September 27, 1929. The floods were the result of two distinct rain events from a tropical storm that began in the Atlantic Ocean, moved westward across the southern part of Florida, and then turned northeast making its way across Georgia, South Carolina, North Carolina, and eventually New England (South Carolina State Climatology Office, undated[a]). Over a 34-hour period ending at 8 a.m. on September 27, 1929, Augusta, Ga., received 7.78 inches of rain (Spencer, 1929). Within a few days, the already saturated soils of the Savannah River Basin received another 9.98 inches

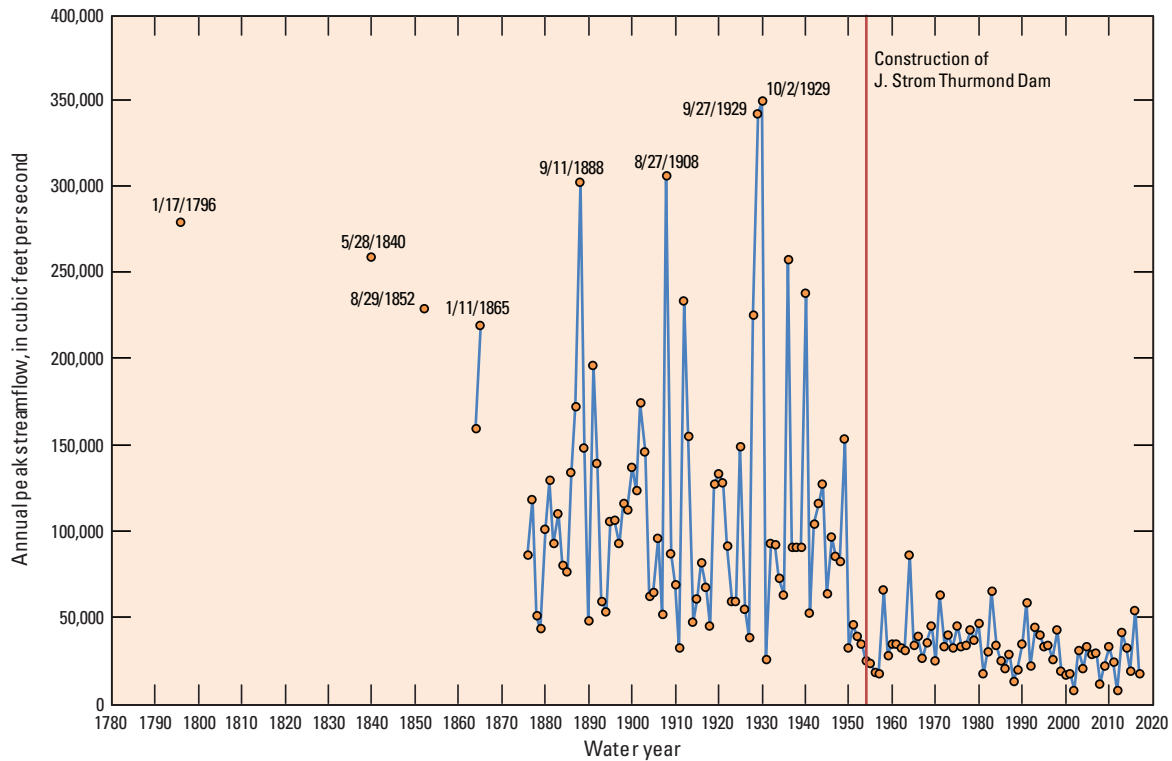

Figure 14. Annual peak streamflows at U.S. Geological Survey streamgage 02197000, Savannah River at Augusta, Ga. [Drainage area is 7,510 square miles.]

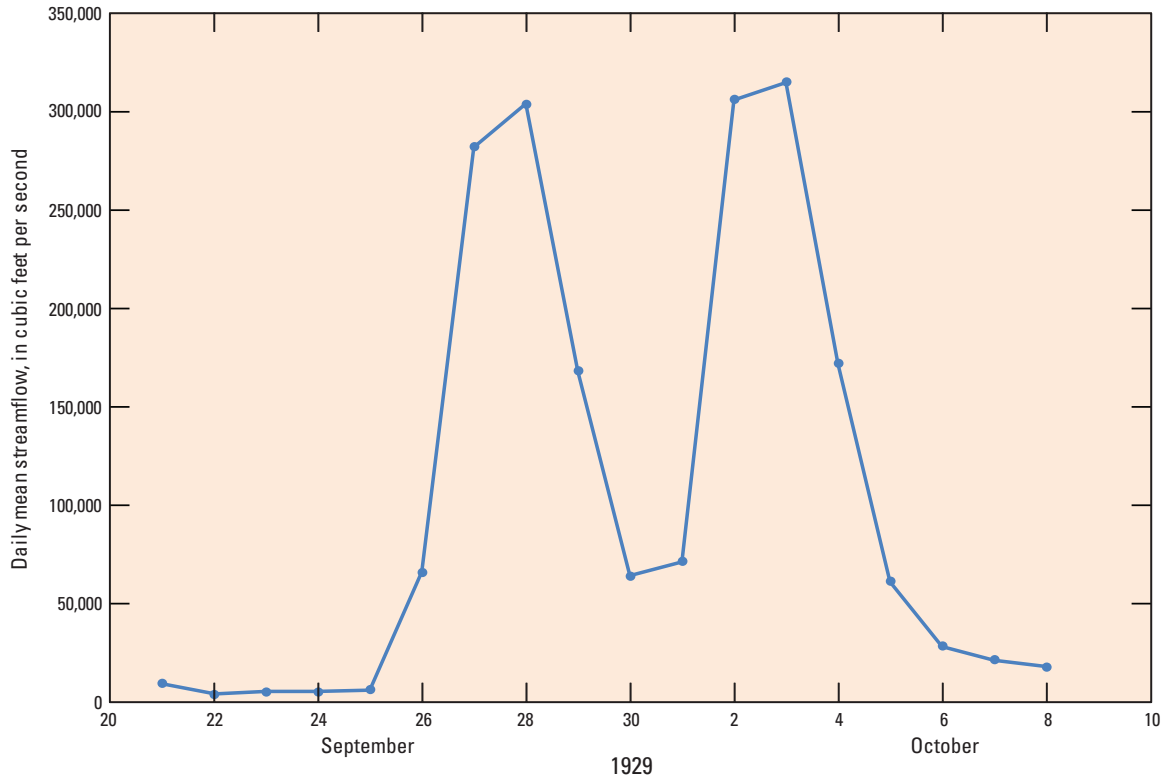

Figure 15. Daily mean streamflows at U.S. Geological Survey streamgage 02197000, Savannah River at Augusta, Ga., for September 21, 1929, to October 8, 1929. [Drainage area is 7,510 square miles.]

of rain for the 30-hour period ending at 6 p.m. on October 2, 1929. The daily mean streamflows at streamgage 02197000 illustrate how the Savannah River peaked on September 28, 1929, receded quickly over the next 2 days, and then peaked again on October 3, 1929, as a result of the second rainfall event (fig. 15).

In North Carolina, streamgage 03451500, French Broad River at Asheville, N.C., has one of the longest peak-streamflow records for an unregulated streamgage, with peak streamflows going back to 1896 (fig. 16). The peak of record for streamgage 03451500 occurred on July 16, 1916, at a peak stage of 23.1 ft and a peak streamflow of 110,000 ft³/s, which is about two and one-half times larger than the second largest peak of record of 43,100 ft³/s at a stage of 14.55 ft that occurred on September 8, 2004. Historic information indicates the 1916 peak was likely the largest peak since at least 1791. The 1916 peak was the result of two tropical storms that brought substantial rain to the region. The first storm came inland along the Mississippi coast during the night of July 5–6, 1916, and initially drifted northwest before turning northeast and drifting across the Appalachian Mountains into the Carolinas (Henry, 1916). For the period July 5–13,

1916, 18.81 inches of rain were recorded in Highlands, N.C. The second tropical storm made landfall at Bulls Bay, S.C., on July 14, 1916 (South Carolina State Climatology Office, undated[b]). The storm moved across South Carolina in a northwestern path. During July 14–18, 1916, the storm brought additional heavy rain on the already saturated French Broad River Basin with more than 17 inches of rain recorded during that period at Blantyre, N.C. An observer in Altapass, N.C., recorded 22.22 inches for the 24-hour period from 2 p.m., July 15–16, 1916 (National Weather Service, 2018a), a new record total for a 24-hour period in North Carolina that remains in effect (State Climate Office of North Carolina, 2018b). The resulting floods brought devastation to the region, causing an estimated 80 fatalities, many of which were in western North Carolina.

For a historical perspective on the floods caused by the heavy rainfall during September 2018 from Hurricane Florence, a chronology of major floods in North Carolina since 1876 and South Carolina since 1893 is presented in table 5 (U.S. Geological Survey, 1985; South Carolina State Climatology Office, undated[b]).

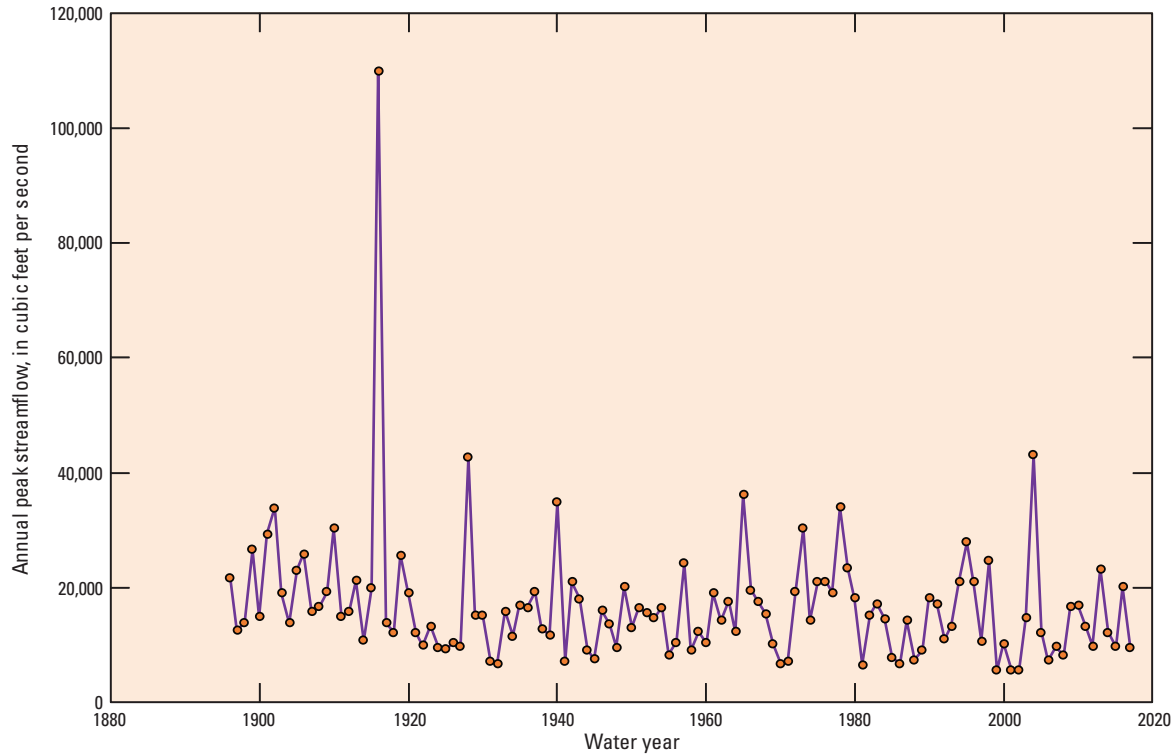

Figure 16. Annual peak streamflows at U.S. Geological Survey streamgage 03451500, French Broad River at Asheville, N.C. [Drainage area is 945 square miles.]

Table 5. Chronology of major floods in North Carolina since 1876 and in South Carolina since 1893.

[Much of the information is from U.S. Geological Survey, 1985, and other sources as noted in Remarks]

Date	Area affected	Remarks
North Carolina		
June 1876	French Broad River	Named the “June Freshet,” it was exceeded only by the 1916 flood at Asheville.
August 1908	Haw, Cape Fear, and Neuse Rivers	Flood of record on Haw and upper Neuse Rivers; stage 34 feet over flood stage on Cape Fear River at Fayetteville.
July 14-16, 1916	Western one-third of State	At the time, the most extensive and destructive flood in State’s history. Excessive rainfall from a tropical cyclone resulted in one of the most extensive and destructive floods in the State’s history. In Altapass, North Carolina, a weather station measured 22.22 inches of rain from 2 p.m. on July 15 to 2 p.m. on July 16. Lives lost across the Southeastern U.S. was estimated about 80, many of which were in western North Carolina. Estimated damage across Southeastern U.S. about \$22 million (Southern Railway Company, 1917, reprinted 1995). Based on lives lost, considered the deadliest hurricane on record for North Carolina (State Climate Office of North Carolina, 2015).
August 15-16, 1928	Broad and French Broad Rivers	More than 10 inches of rain in 2 days.
September 17-18, 1928	Southern Coastal Plain	Flood of record on Lumber River; Cape Fear River 30 feet above flood stage at Fayetteville.
September 15-17, 1933	Middle and northern coast	Storm tides rose 2 feet above previous high-water marks in New Bern. Lives lost, 21; damage, \$3 million.
August 14-17 and 30, 1940	Blue Ridge and western Piedmont, Roanoke River	Floods of record in rivers of northern Blue Ridge Province. Lives lost, 30-40; damage, \$30 million.

Table 5. Chronology of major floods in North Carolina since 1876 and in South Carolina since 1893.—Continued

[Much of the information is from U.S. Geological Survey, 1985, and other sources as noted in Remarks]

Date	Area affected	Remarks
North Carolina—Continued		
September 17, 1945	Coastal Plain and central Piedmont	Floods on upper Neuse, Haw, Cape Fear, Lumber, Rocky, and lower Pee Dee Rivers. Cape Fear River at Fayetteville was 34 feet above flood stage.
October 15, 1954	Eastern Coastal Plain	Hurricane Hazel was the costliest storm in the State’s history. Lives lost, 19; damage, \$125 million.
August 12 and 17, 1955	Middle coast	Hurricanes Connie and Diane. Estuaries of Neuse and Pamlico Rivers hardest hit. Damage, \$58 million.
September 19, 1955	Middle and northern coast	Hurricane Ione caused flooding from New River to Chowan River. Lives lost, 7. Damage, \$88 million.
September 28 and October 4, 1964	Southwestern Blue Ridge	Two floods on the upper French Broad, Little Tennessee, and Hiwassee Rivers caused damage of \$2.7 million.
November 6-7, 1977	Northwestern Blue Ridge	Storm produced 8 to 14 inches of rain. Lives lost, 13; damage, \$50 million.
August 26-28, 1995	Western and central North Carolina	Remnants from Tropical Storm Jerry produced up to 10 inches of rainfall in southwestern North Carolina as well as parts of Charlotte and Mecklenburg County where flood stage records were set. Across the State, damage was \$11 million, and there were 3 fatalities (Wikipedia, 2016a).
September 5-6, 1996	Central and eastern North Carolina	Widespread rainfall totals of 5 to 10+ inches across central and eastern North Carolina resulted in significant flooding. Coupled with hurricane strength winds reaching far inland, substantial damage was caused by toppled trees falling onto structures and power lines. Hurricane Fran was responsible for 24 deaths across the State with damage estimates at \$2.4 billion, making it the fifth deadliest and second costliest hurricane in State history (State Climate Office of North Carolina, 2015).
September 14–17, 1999	Eastern North Carolina	Hurricane Floyd devastated eastern North Carolina with 15 to 20 inches of rain falling across the Coastal Plain, resulting in widespread and catastrophic flooding across the region, including the towns of Rocky Mount, Tarboro, Greenville, and Washington. The flooding was exacerbated by rivers swollen a few weeks earlier when Hurricane Dennis struck North Carolina. At \$8.58 billion in damages, Hurricane Floyd is the costliest hurricane on record for North Carolina. A total of 52 lives were lost in North Carolina, making it the fifth deadliest hurricane in State history (State Climate Office of North Carolina, 2015).
September 8, 2004	Western North Carolina	The remnants of Hurricane Frances moved into the southwestern mountains of North Carolina, resulting in 8 to 15+ inches of rainfall across the Blue Ridge physiographic province, including a maximum reported rainfall of 18.07 inches at Linville Falls, North Carolina (National Oceanic and Atmospheric Administration, date unknown). The heavy rainfall resulted in widespread major flooding across the region, including parts of Asheville and Biltmore Village in Buncombe County. Crop damage in North Carolina was reported at \$55 million, and widespread power outages were reported as well as a major break in the city of Asheville’s water distribution system, leaving the city without water for several days (Wikipedia, 2016b).
September 17, 2004	Western North Carolina	Rainfall of 4 to 8 inches fell across much of western North Carolina as a result of the remnants of Hurricane Ivan. This rain fell on an area that was already saturated from the remnants of Hurricane Frances that had occurred almost 10 days earlier, resulting in repeated flooding of many streams and rivers in the area, including parts of Asheville. Numerous landslides also occurred, including one in the Peeks Creek Basin near Franklin in Macon County that destroyed more than a dozen homes and resulted in five fatalities (State Climate Office of North Carolina, 2015). Combined, Hurricanes Frances (see above) and Ivan resulted in 11 fatalities and about \$252 million in damage in North Carolina (State Climate Office of North Carolina, 2015).

22 Preliminary Peak Stage and Streamflow Data at USGS Streamgages in N.C. and S.C. Following Hurricane Florence

Table 5. Chronology of major floods in North Carolina since 1876 and in South Carolina since 1893.—Continued

[Much of the information is from U.S. Geological Survey, 1985, and other sources as noted in Remarks]

Date	Area affected	Remarks
North Carolina—Continued		
October 7-9, 2016	Central and eastern North Carolina	The passage of Hurricane Matthew across the central and eastern regions of North Carolina and South Carolina during October 7–9, 2016, resulted in rainfall totals of 3 to 8 inches and 8 to more than 15 inches, respectively, across the regions (Weaver and others, 2016). Major flooding occurred in parts of the eastern Piedmont in North Carolina and coastal regions of both States. U.S. Geological Survey streamgages recorded peaks of record at 26 locations, including 11 sites with long-term periods of 30 or more years of record. A total of 44 additional locations had peak streamflows that ranked in the top 5 for the period of record. A total of 28 lives were lost in North Carolina, and five lives were lost in South Carolina. Damages in North Carolina from the storm were estimated at \$1.5 billion (not including state infrastructure and agriculture). In South Carolina, Hurricane Matthew caused nearly \$341 million in damage to public property.
South Carolina		
August 27, 1893	Southern coast of South Carolina	North-northeast through South Carolina Midlands. Winds 96–120 miles per hour; tremendous storm surge; major damage; moved north near Columbia, then north-east. Deaths, 2,000; damage, \$10 million.
June 1903	Santee River Basin (Pacolet River)	Major devastation occurred along the Pacolet River with six textile mills destroyed in Pacolet and Clifton, as well as 70 homes, bridges, churches, businesses, and thousands of bales of cotton. Deaths, at least 65 (some reports indicate up to 80); damage, \$3.5 million.
August 26-30, 1908	Statewide	Most extensive flood in State; rainfall, 12 inches in 24 hours at Anderson.
July 18, 1916	Eastern two-thirds of State	Record rainfall, 13 inches in 24 hours at Effingham; damage, \$10-11 million.
August 15-17, 1928	Statewide	Bridges destroyed, roads and railways impassable.
September 21-24, 1928	Lower Pee Dee River Basin and southern South Carolina	Flooding was severe. Rainfall 10-12 inches. Deaths, 5; damage, \$4-6 million.
October 2, 1929	Savannah and Santee River Basins	Entered Aiken as extratropical storm; intense rains on saturated soil caused severe flooding.
August 11-19, 1940	Statewide	Hurricane related flooding. Deaths, about 34; property and crop damage, \$10 million.
September 17-23, 1945	Statewide	Hurricane related, severe flooding; Deaths, 1; damage, \$6-7 million.
October 15, 1954	Lower Pee Dee River Basin	Hurricane Hazel. One of most severe storms in State to date; Storm surge, 16.9 feet; western half of State having drought. Deaths 1; damage, \$27 million.
September 29-30, 1959	Eastern, southern, and central South Carolina	Hurricane Gracie. Winds 140 miles per hour at landfall. Six foot storm surge. Rainfall, 6-8 inches. Deaths, 7; Excessive property damage along the coast along with heavy crop damage, \$20 million.
November 1, 1969	Coastal, northwest corner	Rainfall, 13.6 inches on Edisto Island. Deaths, 1; flood damage to homes.
June 9-15, 1973	Black and Pocotaligo Rivers	A sub-tropical disturbance remained over Southeast South Carolina for almost a week from June 9-15, 1973. In Clarendon County, 17.5 inches of rain was measured on June 12. At I-95, a few miles north of Manning, water 3 feet deep was running across the southbound lanes.
September 14, 1973	Northwestern South Carolina, Savannah and Santee River Basins	Major flash flood in Laurens; Saluda River at Ware Shoals had highest crest since 1929 flood. Damage, \$4-6 million.
August 19, 1981	Lower Pee Dee River Basin	Hurricane Dennis, greater than 6 inches of rainfall caused significant flood damage in low-lying areas. Greatest flood on upper Waccamaw River since 1945.
September 21, 1989	Eastern two-thirds of State	Hurricane Hugo made landfall at Isle of Palms, S.C. Winds: 140 miles per hour. Gusts: 160 miles per hour. Costliest storm in South Carolina's history. Deaths, 35; damage, more than \$6 billion. Storm surge over 20 feet. Severe inland damage as winds gusted to 109 miles per hour at Sumter, S.C.

Table 5. Chronology of major floods in North Carolina since 1876 and in South Carolina since 1893.—Continued

[Much of the information is from U.S. Geological Survey, 1985, and other sources as noted in Remarks]

Date	Area affected	Remarks
South Carolina—Continued		
October 10-12, 1990	Central South Carolina	The remnants from Tropical Storms Klaus and Marco caused heavy rains and flooding; 10-11 inches rain reported in Spartanburg County; 120 dams failed statewide; 80 bridge failures; Deaths, 5.
October 8-9, 1992	Southern South Carolina	Rainfall, 9 inches in 24 hours. Bridge failures; homes damaged; 90-car train derailed.
August 25-29, 1995	Northwestern Piedmont South Carolina	Tropical Storm Jerry tracked through the upstate of South Carolina, causing flash floods and dumping 8-10 inches of rain in about an 8-hour period. Some rain totals exceeded 20 inches. Several large dams broke causing flooding across the State. Estimated \$4-5 million worth of damage to roads and bridges.
September 16, 1999	Waccamaw and Lower Pee Dee River Basins	Hurricane Floyd: Rainfall was heavy along coastal counties; 12 inches in Georgetown County; 18 inches fell in eastern Horry County. The heavy rains caused flooding to many roads and buildings. Waves were reported to be 15 feet at Cherry Grove where damage was the greatest.
October 1-5, 2015	Midlands and Coastal Plain	Heavy rainfall occurred across South Carolina as a result of an upper atmospheric low-pressure system that funneled tropical moisture from Hurricane Joaquin into the State. About 21.5 inches of rain was recorded in Columbia and almost 27 inches of rain was recorded near Mount Pleasant.
October 7-9, 2016	Central and eastern South Carolina	The passage of Hurricane Matthew across the central and eastern regions of North Carolina and South Carolina during October 7–9, 2016, resulted in rainfall totals of 3 to 8 inches and 8 to more than 15 inches, respectively, across the regions (Weaver and others, 2016). Major flooding occurred in parts of the eastern Piedmont in North Carolina and coastal regions of both States. U.S. Geological Survey streamgages recorded peaks of record at 26 locations, including 11 sites with long-term periods of 30 or more years of record. A total of 44 additional locations had peak streamflows that ranked in the top 5 for the period of record. A total of 28 lives were lost in North Carolina, and five lives were lost in South Carolina. Damages in North Carolina from the storm were estimated at \$1.5 billion (not including State infrastructure and agriculture). In South Carolina, Hurricane Matthew caused nearly \$341 million in damage to public property.

Summary

During September 2018, major flooding occurred on numerous streams and rivers mainly in the central and southern parts of North and South Carolina as a result of Hurricane Florence. Hurricane Florence came ashore just after dawn on September 14, 2018, and then began a slow movement across the Carolinas. Maximum 4-day total rainfalls of almost 36 inches occurred in some parts of North Carolina, setting new statewide rainfall records. Many areas of the State set new State records for rainfall exceeding the previous State record for rainfall from a tropical system of 24.06 inches that was set over a 4-day period in Southport, N.C., during Hurricane Floyd in 1999. In South Carolina, the highest total rainfall from Hurricane Florence of 23.63 inches was reported in Loris, S.C., and was the highest recorded total rainfall from a tropical cyclone, replacing the previous total of

17.45 inches associated with Tropical Storm Beryl in 1994. More than 40 deaths were attributed to Hurricane Florence, and property damage was widespread with early estimates in North Carolina in the range of \$22 billion. In South Carolina, estimated damages are expected to exceed \$1.2 billion.

Peak streamflow and stage data at 84 streamgages in North and South Carolina, collected by the U.S. Geological Survey (USGS), are documented in this report. The streamgages have at least 10 years of systematic record and had peaks for the September 2018 flood ranking in the top 5 for the period of record. New peak streamflow records were set at 28 USGS streamgages, with an additional 49 USGS streamgages having September 2018 peaks ranking in the top 5 for the period of record. In the Pee Dee River Basin, a new peak of record (66,900 cubic feet per second [ft³/s] at a stage of 17.21 feet [ft]) was recorded on September 21, 2018, for streamgage 02135000, Little Pee Dee River at Galivants

Ferry, S.C., and was the largest peak in the 77 years of record. Historical information indicates the September 2018 peak was the largest since at least 1928. In the Waccamaw River Basin, a new peak of record (53,600 ft³/s at a stage of 22.61 ft) was recorded on September 19, 2018, for streamgage 02109500, Waccamaw River at Freeland, N.C., which was the largest peak for the 77 years of record going back to 1940.

For the 28 streamgages for which the September 2018 peak streamflow was the peak of record, at-site flood-frequency estimates were computed using all available peak-streamflow data through September 2017 and including the September 2018 peak from Hurricane Florence. The at-site flood-frequency estimates were weighted with the appropriate USGS regional regression equations and, based on those weighted results, annual exceedance probabilities (AEP) were estimated for the Hurricane Florence peak streamflows. For the 28 streamgages, 9 had floods with an estimated AEP of less than 0.2 percent (greater than a 500-year recurrence interval), 3 had an estimated AEP equal to 0.2 percent (500-year recurrence interval), and 6 had floods with an estimated AEP of between 0.2 and 1 percent (between a 100- and 500-year recurrence interval). The AEP for the remaining 10 streamgages was estimated to be between 1.5 and 7.1 percent (between a 67- and 14-year recurrence interval).

References Cited

- Alexander, A., Cope, C., Off, G., and Schechter, M., 2018, Florence damaged hundreds of SC roads and bridges. When will they be repaired?: The State website (September 22, 2018), accessed September 26, 2018, at <https://www.thestate.com/news/weather/article218812185.html>.
- Badr, A.W., Wachob, A., and Gellici, J.A., 2004, South Carolina water plan, second edition: South Carolina Department of Natural Resources, Land, Water and Conservation Division, 120 p. [Also available at <http://www.dnr.sc.gov/water/hydro/wtrplanerrata.html>.]
- Benson, M.A., and Dalrymple, T., 1967, General field and office procedures for indirect discharge measurements: U.S. Geological Survey Techniques of Water-Resources Investigations, book 3, chap. A1, 30 p. [Also available at <https://doi.org/10.3133/twri03A1>.]
- Bloxham, W.M., 1979, Low-flow frequency and flow duration of South Carolina streams: South Carolina Water Resources Commission Report No. 11, 48 p.
- Bodhaine, G.L., 1968, Measurement of peak discharge at culverts by indirect methods: U.S. Geological Survey Techniques of Water-Resources Investigations, book 3, chap. A3, 60 p. [Also available at <https://pubs.usg.gov/twri/twri3-a3/>.]
- CBS News, 2018, Hurricane Florence death toll rises to 42 as South Carolina expects more record flooding: CBS News website (September 20, 2018), accessed September 26, 2018, at <https://www.cbsnews.com/news/hurricane-florence-flooding-north-south-carolina-virginia-death-toll-today-2018-09-20/>.
- Cohn, T.A., Lane, W.L., and Baier, W.G., 1997, An algorithm for computing moments-based flood quantile estimates when historical flood information is available: Water Resources Research, v. 33, no. 9, p. 2089–2096. [Also available at <https://doi.org/10.1029/97WR01640>.]
- Cohn, T.A., Lane, W.L., and Stedinger, J.R., 2001, Confidence intervals for expected moments algorithm flood quantile estimates: Water Resources Research, v. 37, no. 6, p. 1695–1706. [Also available at <https://doi.org/10.1029/2001WR900016>.]
- Conrads, P.A., Feaster, T.D., and Harrelson, L.G., 2008, The effects of the Saluda Dam on the surface-water and ground-water hydrology of the Congaree National Park flood plain, South Carolina: U.S. Geological Survey Scientific Investigations Report 2008–5170, 58 p. [Also available at <https://pubs.usgs.gov/sir/2008/5170/>.]
- Cooke, C.W., 1936, Geology of the Coastal Plain of South Carolina: U.S. Geological Survey Bulletin 867, 196 p., 2 pls.
- Dalrymple, T., and Benson, M.A., 1967, Measurement of peak discharge by the slope-area method: U.S. Geological Survey Techniques of Water-Resources Investigations, book 3, chap. A2, 12 p. [Also available at <https://pubs.usgs.gov/twri/twri3-a2/>.]
- Duke Energy, 2018, Duke Energy restoring power to remaining 26,000 customers after repairing nearly 1.8 million outages in Carolinas: Duke Energy website (September 21, 2018), accessed September 26, 2018, at https://news.duke-energy.com/releases/duke-energy-restoring-power-to-remaining-26-000-customers-after-repairing-nearly-1-8-million-outages-in-carolinas?_ga=2.95376412.1074249658.1537965382-1307930236.1501670512.
- England, J.F., Jr., Cohn, T.A., Faber, B.A., Stedinger, J.R., Thomas, W.O., Jr., Veilleux, A.G., Kiang, J.E., and Mason, R.R., Jr., 2018, Guidelines for determining flood flow frequency—Bulletin 17C: U.S. Geological Survey Techniques and Methods, book 4, chap. B5, 148 p. [Also available at <https://doi.org/10.3133/tm4B5>.]
- Feaster, T.D., Gotvald, A.J., and Weaver, J.C., 2009, Magnitude and frequency of rural floods in the Southeastern United States, 2006—Volume 3, South Carolina: U.S. Geological Survey Scientific Investigations Report 2009–5156, 226 p. [Also available at <https://pubs.usgs.gov/sir/2009/5156/>.]
- Feaster, T.D., Gotvald, A.J., and Weaver, J.C., 2014, Methods for estimating the magnitude and frequency of floods for urban and small, rural streams in Georgia, South Carolina, and North Carolina, 2011 (ver. 1.1, March 2014): U.S. Geological Survey Scientific Investigations Report 2014–5030, 104 p. [Also available at <https://doi.org/10.3133/sir20145030>.]

- Feaster, T.D., and Koenig, T.A., 2017, Field manual for identifying and preserving high-water mark data: U.S. Geological Survey Open-File Report 2017–1105, 67 p. [Also available at <https://doi.org/10.3133/ofr20171105>.]
- Feaster, T.D., Shelton, J.M., and Robbins, J.C., 2015, Preliminary peak stage and streamflow data at selected USGS streamgaging stations for the South Carolina flood of October 2015 (ver. 1.1, November 2015): U.S. Geological Survey Open-File Report 2015–1201, 19 p. [Also available at <https://doi.org/10.3133/ofr20151201>.]
- Flynn, K.M., Kirby, W.H., and Hummel, P.R., 2006, User’s manual for program PeakFQ, annual flood-frequency analysis using Bulletin 17B guidelines: U.S. Geological Survey Techniques and Methods, book 4, chap. B4, 42 p. [Also available at <https://pubs.usgs.gov/tm/2006/tm4b4/>.]
- Frankenfield, H.C., 1928, Rivers and floods: Monthly Weather Review, v. 56, no. 8, p. 332–334, accessed October 2, 2018, at <https://journals.ametsoc.org/toc/mwre/56/8>.
- Giese, G.L., and Mason, R.R., Jr., 1993, Low-flow characteristics of streams in North Carolina: U.S. Geological Survey Water-Supply Paper 2403, 29 p., 2 pls. [Also available at <https://doi.org/10.3133/wsp2403>.]
- Hart, J., 2018, Ag losses from Florence pegged at \$125 million: Southeast Farm Press, September 24, 2018, accessed September 27, 2018, at <https://www.southeastfarmpress.com/weather/ag-losses-florence-pegged-125-million>.
- Henry, A.J., 1916, Rivers and floods, August, 1916: Monthly Weather Review, August 1916, p. 465–466, accessed October 3, 2018, at <ftp://ftp.library.noaa.gov/docs.lib/htdocs/rescue/mwr/057/mwr-057-10-0435b.pdf>.
- Holmes, R.R., Jr., and Dinicola, K., 2010, 100-year flood—It’s all about chance: U.S. Geological Survey General Information Product 106, 1 p. [Also available at <https://doi.org/10.3133/gip106>.]
- Hulsing, H., 1967, Measurement of peak discharge at dams by indirect methods: U.S. Geological Survey Techniques of Water-Resources Investigations, book 3, chap. A5, 29 p. [Also available at <https://pubs.usgs.gov/twri/twri3-a5/>.]
- Interagency Advisory Committee on Water Data, 1982, Guidelines for determining flood flow frequency, Bulletin 17B of the Hydrology Subcommittee: U.S. Geological Survey, Office of Water Data Coordination, 28 p., 14 apps., 1 oversized sheet.
- Koenig, T.A., Bruce, J.L., O’Connor, J.E., McGee, B.D., Holmes, R.R., Jr., Hollins, R., Forbes, B.T., Kohn, M.S., Schellekens, M.F., Martin, Z.W., and Peppler, M.C., 2016, Identifying and preserving high-water mark data: U.S. Geological Survey Techniques and Methods, book 3, chap. A24, 47 p. [Also available at <https://doi.org/10.3133/tm3A24>.]
- Lurry, D.L., 2011, How does a U.S. Geological Survey streamgage work?: U.S. Geological Survey Fact Sheet 2011–3001, 2 p. [Also available at <http://doi.org/10.3133/fs20113001>.]
- Matthai, H.F., 1967, Measurement of peak discharge at width contractions by indirect methods: U.S. Geological Survey Techniques of Water-Resources Investigations, book 3, chap. A4, 44 p. [Also available at <https://pubs.usgs.gov/twri/twri3-a4/>.]
- National Grain and Feed Association, 2018, North Carolina estimates Hurricane Florence’s ag damage: National Grain and Feed Association newsletter, September 21, 2018, accessed September 26, 2018, at <https://www.ngfa.org/newsletter/north-carolina-estimates-hurricane-florences-ag-damage/>.
- National Oceanic and Atmospheric Administration, [date unknown], Hurricanes in history—Hurricane Frances 2004: National Hurricane Center Web page, accessed December 13, 2016, at <http://www.nhc.noaa.gov/outreach/history/#frances>.
- National Oceanic and Atmospheric Administration, 2018, Historical Hurricane Florence, September 12–15, 2018: National Weather Service website, accessed September 24, 2018, at <https://www.weather.gov/mhx/Florence2018>.
- National Weather Service, 2018a, Flooding in North Carolina: National Weather Service website, accessed October 15, 2018, at <https://www.weather.gov/safety/flood-states-nc>.
- National Weather Service, 2018b, Storm summary for heavy rain and wind associated with Florence: The Weather Prediction Center web page (September 19, 2018), accessed September 27, 2018, at <https://www.wpc.ncep.noaa.gov/discussions/nfdsc4.html>.
- North Carolina Department of Public Safety, 2018, Hurricane Florence claims three lives in North Carolina: North Carolina Department of Public Safety press release, September 14, 2018, accessed September 20, 2018, at <https://www.ncdps.gov/news/press-releases/2018/09/14/hurricane-florence-claims-three-lives-north-carolina>.
- Omernik, J.M., 1987, Ecoregions of the conterminous United States: Annals of the Association of American Geographers, v. 77, no. 1, p. 118–125. [Also available at <https://doi.org/10.1111/j.1467-8306.1987.tb00149.x>.]
- Samenow, J., 2018, Hurricane Florence’s assault begins as wind gusts top 105 mph on Outer Banks, waters rise 10 feet: The Washington Post, September 14, 2018, accessed September 25, 2018, at https://www.washingtonpost.com/news/capital-weather-gang/wp/2018/09/13/hurricane-florence-set-to-begin-dangerous-assault-from-rain-and-wind-in-the-carolinas/?noredirect=on&utm_term=.3d48f19f07a4.
- SCE&G, 2018, SCE&G reminds customers to be safe during severe weather: SCE&G website, accessed October 3, 2018, at <https://www.sceg.com/about-us/newsroom/2015/10/04/sce-g-reminds-customers-to-be-safe-during-severe-weather>.
- Smith, T., 2018, Hurricane Florence, another 1,000-year event, caused at least \$1.2 billion in damage in SC: Greenville News, September 20, 2018, accessed September 26, 2018, at <https://www.greenvilleonline.com/story/news/local/south-carolina/2018/09/20/south-carolina-damage-florence-estimated-1-2-billion/1368815002/>.

- South Carolina State Climatology Office, 2018, Hurricane Florence—Preliminary Open File Report: South Carolina Department of Natural Resources, 8 p., accessed September 26, 2018, at http://www.dnr.sc.gov/climate/sco/Publications/FlorenceQuickReport_100518.pdf.
- South Carolina State Climatology Office, undated[a], Hurricane #2, September 22–October 4, 1929: South Carolina State Climatology Office website, accessed October 3, 2018, at http://www.dnr.sc.gov/climate/sco/Tropics/pastTracks/Hurr2_1929.php.
- South Carolina State Climatology Office, undated[b], Hurricanes and tropical storms affecting South Carolina 1910–1919: South Carolina State Climatology Office website, accessed October 3, 2018, at <http://www.dnr.sc.gov/climate/sco/Tropics/1910s.php>.
- Southern Railway Company, 1917, The floods of July, 1916—How the Southern Railway Organization met an emergency: Southern Railway Company, 131 p. (Reprinted in 1995 by The Overmountain Press.)
- Spencer, R.E., 1929, Rivers and floods: Monthly Weather Review, v. 57, no. 10, p. 435–437, accessed October 2, 2018, at <https://journals.ametsoc.org/toc/mwre/57/10>.
- State Climate Office of North Carolina, 2015, NC extremes—Damaging hurricanes from slopes to shores: State Climate Office of North Carolina Web page, accessed November 12, 2016, at <http://climate.ncsu.edu/climateblog?id=157>.
- State Climate Office of North Carolina, 2016, Averages and normals: State Climate Office of North Carolina website, accessed November 1, 2016, at <https://climate.ncsu.edu/edu/Normals>.
- State Climate Office of North Carolina, 2018a, Rapid reaction—Record rainfall and flooding follow Florence: State Climate Office of North Carolina website (September 18, 2018), accessed September 25, 2018, at <http://climate.ncsu.edu/climateblog?id=266>.
- State Climate Office of North Carolina, 2018b, Weather extremes: State Climate Office of North Carolina website, accessed October 24, 2018, at http://climate.ncsu.edu/nc_extremes.
- Sweat, C., 2018, When agriculture hurts, everybody hurts—Florence caused \$1.1B in NC agriculture losses: WRAL website (September 26, 2018), accessed September 27, 2018, at <https://www.wral.com/florence-caused-1-1b-in-nc-agriculture-losses/17875342/>.
- Turnipseed, D.P., and Sauer, V.B., 2010, Discharge measurements at gaging stations: U.S. Geological Survey Techniques and Methods book 3, chap. A8, 87 p. [Also available at <https://pubs.usgs.gov/tm/tm3-a8/>.]
- U.S. Geological Survey, 1985, National Water Summary 1988–89, Hydrologic events and floods and droughts: U.S. Geological Survey Water-Supply Paper 2375, 591 p. [Also available at <https://doi.org/10.3133/wsp2375>.]
- U.S. Geological Survey, 2012, Computation of annual exceedance probability (AEP) for characterization of observed flood peaks: U.S. Geological Survey Office of Surface Water Technical Memorandum 2013.01, accessed March 6, 2018, at <https://water.usgs.gov/admin/memo/SW/sw13.01.pdf>.
- U.S. Geological Survey, 2014a, Number of USGS streamgages through time: USGS National Streamflow Information Program web page, accessed October 9, 2018, at <http://water.usgs.gov/nsip/history1.html>.
- U.S. Geological Survey, 2014b, Weighting estimates of peak-flow-frequency when using the expected moments algorithm for at-site flood-frequency estimation: Office of Surface Water Informational and Technical Note 2014.43, 8 p., accessed October 10, 2018, at https://water.usgs.gov/floods/usgs/OSW_Note_2014.43.pdf.
- Veilleux, A.G., Cohn, T.A., Flynn, K.M., Mason, R.R., Jr., and Hummel, P.R., 2014, Estimating magnitude and frequency of floods using the PeakFQ 7.0 program: U.S. Geological Survey Fact Sheet 2013–3108, 2 p. [Also available at <https://doi.org/10.3133/fs20133108>.]
- Weaver, J.C., Feaster, T.D., and Gotvald, A.J., 2009, Magnitude and frequency of rural floods in the Southeastern United States, through 2006—Volume 2, North Carolina: U.S. Geological Survey Scientific Investigations Report 2009–5158, 111 p. [Also available at <https://pubs.usgs.gov/sir/2009/5158/>.]
- Weaver, J.C., Feaster, T.D., and Robbins, J.C., 2016, Preliminary peak stage and streamflow data at selected streamgaging stations in North Carolina and South Carolina for flooding following Hurricane Matthew, October 2016: U.S. Geological Survey Open-File Report 2016–1205, 38 p. [Also available at <https://doi.org/10.3133/ofr20161205>.]
- Wikipedia, 2016a, Tropical Storm Jerry (1995): Wikipedia® web page, accessed December 2, 2016, at [https://en.wikipedia.org/wiki/Tropical_Storm_Jerry_\(1995\)](https://en.wikipedia.org/wiki/Tropical_Storm_Jerry_(1995)). [Wikipedia is a registered trademark of the Wikimedia Foundation, Inc.]
- Wikipedia, 2016b, Hurricane Frances: Wikipedia® web page, accessed December 2, 2016, at https://en.wikipedia.org/wiki/Hurricane_Frances. [Wikipedia is a registered trademark of the Wikimedia Foundation, Inc.]
- Winner, M.D., Jr., and Coble, R.W., 1996, Hydrogeologic framework of the North Carolina Coastal Plain, in Regional Aquifer-System Analysis—Northern Atlantic Coastal Plain: U.S. Geological Survey Professional Paper 1404-I, 106 p., 24 pls. [Also available at <https://pubs.usgs.gov/pp/1404i/report.pdf>.]

Table 1. Preliminary peak stage and streamflow data at streamgages in North Carolina and South Carolina with at least 10 years of record and where new or top 5 peak streamflow record was set during the flood of September 2018 following Hurricane Florence.

[USGS, U.S. Geological Survey; °, degrees; ', minutes; ", seconds; NAD27, North American Datum of 1927; NAD83, North American Datum of 1983; mi², square miles; ft, feet; ft³/s, cubic feet per second; —, data not available; n/a, not applicable; n/d, not determined; Hurr, hurricane. Yellow shading indicates streamgages for which the September 2018 flood peak was the new peak of record; no shading indicates streamgages that recorded peaks that ranked in the top 5 for the period of record; tan shading indicates stage-only sites that recorded peak stage records. Period of record is given in water years, which is the period October 1–September 30 and is identified by the year in which the period ends. Number of annual peak streamflows in record used for rank comparison includes the preliminary 2018 water year peak associated with the September 2018 flood]

Site index number (fig. 5)	USGS station number	Station name	Latitude	Longitude	Horizontal datum	Contributing drainage area, in mi ²	Flood data				Remarks					
							Previous maximum		Period of record for annual peak streamflows	Flood of September 2018			National Weather Service flood stage, in ft			
							Date of peak streamflow	Peak stage, in ft		Peak streamflow, in ft ³ /s		Rank / number of annual peak streamflows in record		Date of peak streamflow	Peak stage, in ft	Peak streamflow, in ft ³ /s
Roanoke River Basin																
1	02069000	DAN RIVER AT PINE HALL, NC	36°19'09"	80°03'01"	NAD27	501	1/25/2010	25.77	27,800	1987-90; 2009-17	3 / 14	9/17/2018	24.91	20,500	—	
Tar-Pamlico River Basin																
2	02081500	TAR RIVER NEAR TAR RIVER, NC	36°11'39"	78°34'59"	NAD83	167	9/6/1996 (Hurr Fran)	24.06	19,900	1940-2017	2 / 79	9/18/2018	20.04	14,500	16	
3	02084160	CHICOD CR AT SR1760 NEAR SIMPSON, NC	35°33'42"	77°13'51"	NAD83	45	10/9/2016 (Hurr Matthew)	17.82	7,810	1976-87; 1992-2017	5 / 39	9/15/2018	14.14	4,010	11.5	
Neuse River Basin																
4	02085070	ENO RIVER NEAR DURHAM, NC	36°04'20"	78°54'28"	NAD83	141	9/6/1996 (Hurr Fran)	23.58	14,700	1964-2017	2 / 55	9/17/2018	23.06	13,700	20	
5	0208521324	LITTLE RIVER AT SR1461 NEAR ORANGE FACTORY, NC	36°08'30"	78°55'09"	NAD83	78.2	9/6/1996 (Hurr Fran)	13.26	11,600	1988-2017	2 / 31	9/17/2018	10.91	8,550	12	Period of record for annual peak streamflows represents combined streamflow records for this site and discontinued streamgage USGS station 02085220 Little River near Orange Factory (drainage area 80.4 mi ²).
6	0208524090	MOUNTAIN CREEK AT SR1617 NR BAHAMA, NC	36°08'59"	78°53'48"	NAD83	7.97	10/11/2002	12.07	2,680	1995; 1997-2017	1 / 23	9/17/2018	12.92	3,370	10	
7	0208524975	LITTLE R BL LITTLE R TRIB AT FAIRNTOSH, NC	36°06'48"	78°51'35"	NAD83	98.9	9/6/1996 (Hurr Fran)	17.27	16,600	1996-2017	2 / 23	9/17/2018	16.04	13,600	—	Streamflow regulated by releases from the Little River Reservoir.
8	02086500	FLAT RIVER AT DAM NEAR BAHAMA, NC	36°08'55"	78°49'44"	NAD83	168	9/6/1996 (Hurr Fran)	23.48	20,900	1928-59; 1962-66; 1983-93; 1996; 2001-17	3 / 67	9/17/2018	19.27	15,000	16	Streamflow regulated by Lake Michie.

Table 1. Preliminary peak stage and streamflow data at streamgages in North Carolina and South Carolina with at least 10 years of record and where new or top 5 peak streamflow record was set during the flood of September 2018 following Hurricane Florence.—Continued

[USGS, U.S. Geological Survey; °, degrees; ', minutes; ", seconds; NAD27, North American Datum of 1927; NAD83, North American Datum of 1983; mi², square miles; ft, feet; ft³/s, cubic feet per second; —, data not available; n/d, not applicable; n/d, not determined; Hurr, hurricane. Yellow shading indicates streamgages for which the September 2018 flood peak was the new peak of record; no shading indicates streamgages that recorded peaks that ranked in the top 5 for the period of record; tan shading indicates stage-only sites that recorded peak stage records. Period of record is given in water years, which is the period October 1–September 30 and is identified by the year in which the period ends. Number of annual peak streamflows in record used for rank comparison includes the preliminary 2018 water year peak associated with the September 2018 flood]

Site index number (fig. 5)	USGS station number	Station name	Latitude	Longitude	Horizontal datum	Contributing drainage area, in mi ²	Flood data				National Weather Service flood stage, in ft	Remarks				
							Previous maximum		Period of record for annual peak streamflows	Flood of September 2018						
							Date of peak streamflow	Peak stage, in ft		Peak streamflow, in ft ³ /s			Rank / number of annual peak streamflows in record	Date of peak streamflow	Peak stage, in ft	Peak streamflow, in ft ³ /s
Neuse River Basin—Continued																
9	02086624	KNAP OF REEDS CREEK NEAR BUTNER, NC	36°07'40"	78°47'55"	NAD27	43	7/16/1989	8.79	8.600	1983-95; 2006-17	n/d	9/17/2018	9.94	n/d	—	Peak streamflow not determined prior to report publication. Peak stage recorded during September 2018 flood is new period of record peak stage at this streamgage.
10	02086849	ELLERBE CREEK NEAR GORMAN, NC	36°03'33"	78°49'58"	NAD27	21.9	10/8/2016 (Hurr Matthew)	12.95	3,130	1983-88; 1992-94; 2006-07; 2009-17	1 / 21	9/17/2018	12.96	3,140	—	Following occurrence of peak streamflow from runoff, streamflows were affected by backwater conditions from Falls Lake.
11	02089000	NEUSE RIVER NEAR GOLDSBORO, NC	35°20'15"	77°59'51"	NAD83	2,399	10/12/2016 (Hurr Matthew)	29.74	53,400	1930-2017	4 / 89	9/19/2018	27.60	36,700	18	Streamflow regulated since December 1983 by Falls Lake.
12	02091000	NAHUNTA SWAMP NEAR SHINE, NC	35°29'20"	77°48'22"	NAD83	80.4	9/17/1999 (Hurr Floyd)	21.00	23,000	1955-2017	3 / 64	9/15/2018	14.52	6,060	17	
13	02091500	CONTENTNEA CREEK AT HOOKERTON, NC	35°25'44"	77°34'57"	NAD83	733	9/18/1999 (Hurr Floyd)	28.28	31,900	1929-2017	4 / 90	9/20/2018	18.98	11,700	13	
14	02091814	NEUSE RIVER NEAR FORT BARNWELL, NC	35°18'50"	77°18'10"	NAD83	3,900	9/20/1999 (Hurr Floyd)	22.75	57,200	1997-2017	3 / 22	9/22/2018	18.00	40,300	13	Streamflow regulated since December 1983 by Falls Lake; tidally influenced, which is overcome by basin runoff at high flows.
15	02092500	TRENT RIVER NEAR TRENTON, NC	35°03'51"	77°27'41"	NAD83	168	9/17/1999 (Hurr Floyd)	22.33	15,000	1928; 1952-2017	1 / 67	9/16/2018	24.23	67,700	14	Peak stage determined from high-water mark identified at site after event; estimated peak streamflow based on provisional rating-curve extension.

Table 1. Preliminary peak stage and streamflow data at streamgages in North Carolina and South Carolina with at least 10 years of record and where new or top 5 peak streamflow record was set during the flood of September 2018 following Hurricane Florence.—Continued

[USGS, U.S. Geological Survey; °, degrees; ', minutes; ", seconds; NAD27, North American Datum of 1927; NAD83, North American Datum of 1983; mi², square miles; ft, feet; ft³/s, cubic feet per second; —, data not available; n/a, not applicable; n/d, not determined; Hurr, hurricane. Yellow shading indicates streamgages for which the September 2018 flood peak was the new peak of record; no shading indicates streamgages that recorded peaks that ranked in the top 5 for the period of record; tan shading indicates stage-only sites that recorded peak stage records. Period of record is given in water years, which is the period October 1–September 30 and is identified by the year in which the period ends. Number of annual peak streamflows in record used for rank comparison includes the preliminary 2018 water year peak associated with the September 2018 flood]

Site index number (fig. 5)	USGS station number	Station name	Latitude	Longitude	Horizontal datum	Contributing drainage area, in mi ²	Flood data					Remarks				
							Previous maximum		Period of record for annual peak streamflows	Flood of September 2018			National Weather Service flood stage, in ft			
							Date of peak streamflow	Peak stage, in ft		Peak streamflow, in ft ³ /s	Rank / number of annual peak streamflows in record			Date of peak streamflow	Peak stage, in ft	Peak streamflow, in ft ³ /s
Neuse River Basin—Continued																
16	02092554	TRENT AT POLLOCKSVILLE, NC	35°00'36"	77°13'08"	NAD83	370	9/19/1999 (Hurr Floyd)	16.29	18.600	1996-2005	n/a	9/18/2018	20.48	n/a	5	Stage-only records available for site since July 2008; tidally influenced, which is overcome by basin runoff at high flows. Peak stage determined from high-water mark identified at site after event, which is almost identical with average of two other high-water marks (20.13 ft, 20.85 ft) surveyed in nearby town.
Cape Fear River Basin																
17	02093000	NEW RIVER NEAR GUM BRANCH, NC	34°50'57"	77°31'10"	NAD83	94	9/16/1999 (Hurr Floyd)	25.12	15,000	1950-73; 1988-2017	n/d	9/15/2018	25.76	n/d	14	Peak streamflow not determined prior to report publication. Peak stage recorded during September 2018 flood is new period of record peak stage at this streamgage. Tidally influenced, which is overcome by basin runoff at high flows.
18	02093800	REEDY FORK NEAR OAK RIDGE, NC	36°10'21"	79°57'10"	NAD83	20.6	10/10/1959	10.94	3,950	1956-2017	2 / 63	9/17/2018	13.68	3,260	10	
19	02093877	BRUSH CREEK AT MUIRFIELD RD AT GREENSBORO, NC	36°07'41"	79°55'26"	NAD83	5.3	3/28/2010	9.98	672	2005-17	1 / 14	9/17/2018	11.10	907	9	
20	020939200	HORSEPEN CREEK AT US 220 NR GREENSBORO, NC	36°08'16"	79°51'36"	NAD83	15.9	9/23/2003	10.66	2,800	2000-01; 2003-17	3 / 18	9/17/2018	11.94	2,280	11	
21	02094500	REEDY FORK NEAR GIBSONVILLE, NC	36°10'23"	79°36'51"	NAD83	131	9/25/1947	20.77	11,600	1916; 1929-2017	2 / 91	9/17/2018	18.51	9,180	—	Streamflow regulated since 1970 water year by series of four upstream reservoirs.

Table 1. Preliminary peak stage and streamflow data at streamgages in North Carolina and South Carolina with at least 10 years of record and where new or top 5 peak streamflow record was set during the flood of September 2018 following Hurricane Florence.—Continued

[USGS, U.S. Geological Survey; °, degrees; ', minutes; ", seconds; NAD27, North American Datum of 1927; NAD83, North American Datum of 1983; mi², square miles; ft, feet; ft³/s, cubic feet per second; —, data not available; n/a, not applicable; n/d, not determined; Hurr, hurricane. Yellow shading indicates streamgages for which the September 2018 flood peak was the new peak of record; no shading indicates streamgages that recorded peaks that ranked in the top 5 for the period of record; tan shading indicates stage-only sites that recorded peak stage records. Period of record is given in water years, which is the period October 1–September 30 and is identified by the year in which the period ends. Number of annual peak streamflows in record used for rank comparison includes the preliminary 2018 water year peak associated with the September 2018 flood]

Site index number (fig. 5)	USGS station number	Station name	Latitude	Longitude	Horizontal datum	Contributing drainage area, in mi ²	Flood data				National Weather Service flood stage, in ft	Remarks				
							Previous maximum		Period of record for annual peak streamflows	Flood of September 2018						
							Date of peak streamflow	Peak stage, in ft		Peak streamflow, in ft ³ /s			Rank / number of annual peak streamflows in record	Date of peak streamflow	Peak stage, in ft	Peak streamflow, in ft ³ /s
Cape Fear River Basin—Continued																
22	02094659	SOUTH BUFFALO CREEK NR POMONA, NC	36°02'58"	79°51'19"	NAD83	7.33	9/23/2003	15.45	3.350	1999; 2000-17	4 / 20	9/17/2018	14.64	3,020	11	
23	02094770	SOUTH BUFFALO CREEK AT US 220 AT GREENSBORO, NC	36°02'17"	79°47'59"	NAD83	15.4	9/23/2003	16.44	2,770	1999; 2000-17	1 / 20	9/17/2018	16.77	3,340	18	
24	02094775	RYAN CREEK BELOW US 220 AT GREENSBORO, NC	36°01'52"	79°47'46"	NAD83	4.12	7/13/2003	12.53	1,060	1999; 2000-17	1 / 20	9/17/2018	11.78	1,180	8	
25	02095000	SOUTH BUFFALO CR NEAR GREENSBORO, NC	36°03'36"	79°43'33"	NAD83	34	7/15/1949	11.54	10,000	1929-37; 1939-58; 1999-2017	3 / 49	9/17/2018	16.40	5,860	17	
26	02095181	N BUFFALO CR AT WESTOVER TERRACE AT GREENSBORO, NC	36°04'45"	79°48'46"	NAD83	9.55	9/23/2003	14.07	2,520	1999; 2000-17	4 / 20	9/17/2018	12.85	2,160	10	
27	02095271	NORTH BUFFALO CREEK AT CHURCH ST AT GREENSBORO, NC	36°05'52"	79°46'57"	NAD83	14.2	9/23/2003	17.81	3,520	1998-2017	2 / 21	9/17/2018	17.73	3,480	14	
28	0209553650	BUFFALO CREEK AT SR2819 NR MCLEANSVILLE, NC	36°07'41"	79°39'42"	NAD83	88.5	3/20/2003	19.35	6,720	1999; 2000-17	1 / 20	9/17/2018	21.45	9,450	—	
29	02096960	HAW RIVER NEAR BYNUM, NC	35°45'55"	79°08'09"	NAD83	1,275	9/6/1996 (Hurr Fran)	21.76	76,700	1974-2017	2 / 45	9/17/2018	17.62	51,900	11	Peak stage determined from high-water mark identified at site after event.
30	02097314	NEW HOPE CREEK NEAR BLANDS, NC	35°53'06"	78°57'55"	NAD83	75.9	12/30/2015	14.06	15,300	1983-2017	2 / 36	9/17/2018	14.07	15,300	—	Following occurrence of peak streamflow from runoff, peak stage reached 17.49 ft, as affected by backwater conditions from B. Everett Jordan Lake.

Table 1. Preliminary peak stage and streamflow data at streamgages in North Carolina and South Carolina with at least 10 years of record and where new or top 5 peak streamflow record was set during the flood of September 2018 following Hurricane Florence.—Continued

[USGS, U.S. Geological Survey; °, degrees; ', minutes; ", seconds; NAD27, North American Datum of 1927; NAD83, North American Datum of 1983; mi², square miles; ft, feet; ft³/s, cubic feet per second; —, data not available; n/a, not applicable; n/d, not determined; Hurr, hurricane. Yellow shading indicates streamgages for which the September 2018 flood peak was the new peak of record; no shading indicates streamgages that recorded peaks that ranked in the top 5 for the period of record; tan shading indicates stage-only sites that recorded peak stage records. Period of record is given in water years, which is the period October 1–September 30 and is identified by the year in which the period ends. Number of annual peak streamflows in record used for rank comparison includes the preliminary 2018 water year peak associated with the September 2018 flood]

Site index number (fig. 5)	USGS station number	Station name	Latitude	Longitude	Horizontal datum	Contributing drainage area, in mi ²	Flood data				National Weather Service flood stage, in ft	Remarks			
							Previous maximum		Period of record for annual peak streamflows	Flood of September 2018					
							Date of peak streamflow	Peak stage, in ft		Peak streamflow, in ft ³ /s			Rank / number of annual peak streamflows in record	Date of peak streamflow	Peak stage, in ft
Cape Fear River Basin—Continued															
31	0209741955	NORTHEAST CREEK AT SRI100 NR GENLEE, NC	35°52'20"	78°54'47"	NAD83	21.1	9/6/1996 (Hurr Fran)	13.92	5,140	1983-93; 1996-2003; 2006-17	9/17/2018	11.28	2,930	—	
32	02097517	MORGAN CREEK NEAR CHAPEL HILL, NC	35°53'36"	79°01'11"	NAD83	41	9/6/1996 (Hurr Fran)	16.18	4,210	1983-2017	9/17/2018	16.17	4,200	—	Peak stage determined from high-water mark identified at site after event.
33	0209782609	WHITE OAK CR AT MOUTH NEAR GREEN LEVEL, NC	35°45'37"	78°55'13"	NAD83	11.9	6/14/2006	13.50	5,920	2000-17	9/17/2018	11.07	1,730	—	Annual peak streamflow and stage not determined for 2007 water year.
34	0210166029	ROCKY R AT SRI300 NR CRUTCHFIELD CROSSROADS, NC	35°48'25"	79°31'39"	NAD83	7.42	12/30/2015	9.86	1,760	1989-2006; 2008-17	9/17/2018	9.01	1,030	—	Peak streamflow not determined prior to report publication. Peak stage recorded during September 2018 flood is 2nd highest for period of record at this streamgage.
35	02101800	TICK CREEK NEAR MOUNT VERNON SPRINGS, NC	35°39'35"	79°24'06"	NAD83	15.5	9/6/1996 (Hurr Fran)	13.41	4,010	1959-81; 1994-2017	9/17/2018	12.62	n/d	—	Since December 1980, considerable regulation by Harris Lake.
36	02102000	DEEP RIVER AT MONCURE, NC	35°37'37"	79°06'58"	NAD83	1,434	9/18/1945	17.20	80,300	1931-2017	9/17/2018	15.21	64,500	9	
37	02102192	BUCKHORN CREEK NR CORINTH, NC	35°33'35"	78°58'25"	NAD83	76.3	2/2/1973	20.02	6,920	1973-2017	9/17/2018	13.75	2,860	—	
38	02102908	FLAT CREEK NEAR INVERNESS, NC	35°10'58"	79°10'39"	NAD83	7.63	10/8/2016 (Hurr Matthew)	8.63	733	1969-2017	9/17/2018	9.36	826	7	
39	02103000	LITTLE RIVER AT MANCHESTER, NC	35°11'36"	78°59'08"	NAD83	348	10/10/2016 (Hurr Matthew)	32.19	10,500	1939-44; 1946-50; 2003-17	9/18/2018	38.30	16,200	18	Peak stage determined from high-water mark identified at nearby structure after event; estimated peak streamflow based on provisional rating-curve extension.

Table 1. Preliminary peak stage and streamflow data at streamgages in North Carolina and South Carolina with at least 10 years of record and where new or top 5 peak streamflow record was set during the flood of September 2018 following Hurricane Florence.—Continued

[USGS, U.S. Geological Survey; °, degrees; ', minutes; ", seconds; NAD27, North American Datum of 1927; NAD83, North American Datum of 1983; mi², square miles; ft, feet; ft³/s, cubic feet per second; —, data not available; n/a, not applicable; n/d, not determined; Hurr, hurricane. Yellow shading indicates streamgages for which the September 2018 flood peak was the new peak of record; no shading indicates streamgages that recorded peaks that ranked in the top 5 for the period of record; tan shading indicates stage-only sites that recorded peak stage records. Period of record is given in water years, which is the period October 1–September 30 and is identified by the year in which the period ends. Number of annual peak streamflows in record used for rank comparison includes the preliminary 2018 water year peak associated with the September 2018 flood]

Site index number (fig. 5)	USGS station number	Station name	Latitude	Longitude	Horizontal datum	Contributing drainage area, in mi ²	Flood data				Remarks				
							Previous maximum		Period of record for annual peak streamflows	Flood of September 2018			National Weather Service flood stage, in ft		
							Date of peak streamflow	Peak stage, in ft		Peak streamflow, in ft ³ /s		Rank / number of annual peak streamflows in record		Date of peak streamflow	Peak stage, in ft
Cape Fear River Basin—Continued															
40	02104000	CAPE FEAR RIVER AT FAYETTEVILLE, NC	35°02'50"	78°51'29"	NAD83	4,395	10/9/2016 (Hurr Matthew)	58.94	n/a	n/a	9/19/2018	61.58	n/a	35	Stage-only records available for site since October 1986, streamflow regulated since September 1981 by B. Everett Jordan Lake. Maximum observed stage of 68.8 feet on September 20, 1945, occurred during period of record prior to regulation
41	02104220	ROCKFISH CREEK AT RAEFORD, NC	34°59'59"	79°12'53"	NAD83	93.1	10/9/2016 (Hurr Matthew)	12.94	5,490	1989-2017	9/17/2018	10.32	2,130	15	
42	02105500	CAPE FEAR R AT WILM O HUSKE LOCK NR TARHEEL, NC	34°50'08"	78°49'25"	NAD83	4,852	10/10/2016 (Hurr Matthew)	35.90	81,000	1941-44; 1947; 1950-95; 1997-2004; 2006-12; 2014-17	9/19/2018	38.66	87,400	42	Streamflow regulated since September 1981 by B. Everett Jordan Lake.
43	02105769	CAPE FEAR R AT LOCK #1 NR KELLY, NC	34°24'16"	78°17'37"	NAD83	5,255	10/13/2016 (Hurr Matthew)	28.62	66,600	1970-2017	9/21/2018	30.68	76,700	24	Streamflow regulated since September 1981 by B. Everett Jordan Lake.
44	02106500	BLACK RIVER NEAR TOMAHAWK, NC	34°45'18"	78°17'19"	NAD83	676	10/10/2016 (Hurr Matthew)	27.92	39,100	1928; 1945; 1948; 1952-2017	9/18/2018	31.34	54,700	18	Peak stage determined from high-water mark identified at site after event; estimated peak streamflow based on provisional rating-curve extension.
45	02108000	NORTHEAST CAPE FEAR RIVER NEAR CHINQUAPIN, NC	34°49'44"	77°49'56"	NAD83	599	9/18/1999 (Hurr Floyd)	23.51	30,700	1941-2017	9/17/2018	25.77	41,300	13	Peak stage determined from high-water mark identified at site after event.
46	02108566	NORTHEAST CAPE FEAR RIVER NEAR BURGAW, NC	34°35'54"	77°52'31"	NAD83	920	9/20/1999 (Hurr Floyd)	22.77	n/a	n/a	9/19/2018	25.58	n/a	—	Stage-only records available for site since December 2005; tidally influenced, which is overcome by basin runoff at high flows.

Table 1. Preliminary peak stage and streamflow data at streamgages in North Carolina and South Carolina with at least 10 years of record and where new or top 5 peak streamflow record was set during the flood of September 2018 following Hurricane Florence.—Continued

[USGS, U.S. Geological Survey; °, degrees; ', minutes; ", seconds; NAD27, North American Datum of 1927; NAD83, North American Datum of 1983; mi², square miles; ft, feet; ft³/s, cubic feet per second; —, data not available; n/a, not applicable; n/d, not determined; Hurr, hurricane. Yellow shading indicates streamgages for which the September 2018 flood peak was the new peak of record; no shading indicates streamgages that recorded peaks that ranked in the top 5 for the period of record; tan shading indicates stage-only sites that recorded peak stage records. Period of record is given in water years, which is the period October 1–September 30 and is identified by the year in which the period ends. Number of annual peak streamflows in record used for rank comparison includes the preliminary 2018 water year peak associated with the September 2018 flood]

Site index number (fig. 5)	USGS station number	Station name	Latitude	Longitude	Horizontal datum	Contributing drainage area, in mi ²	Flood data					National Weather Service flood stage, in ft	Remarks			
							Previous maximum		Period of record for annual peak streamflows	Flood of September 2018						
							Date of peak streamflow	Peak stage, in ft		Peak streamflow, in ft ³ /s	Rank / number of annual peak streamflows in record			Date of peak streamflow	Peak stage, in ft	Peak streamflow, in ft ³ /s
Yadkin-Pee Dee River Basin																
47	02109500	WACCAMAW RIVER AT FREELAND, NC	34°05'42"	78°32'54"	NAD83	680	9/21/1999 (Hurr Floyd)	19.30	31,200	1940-2012; 2015-17	1 / 77	9/19/2018	22.61	53,600	—	Peak stage determined from high-water mark identified at site after event.
48	02110400	BUCK CREEK NEAR LONGS, SC	33°57'12"	78°43'12"	NAD27	49.4	10/9/2016 (Hurr Matthew)	16.85	5,140	2006-13; 2015-17	2 / 12	9/16/2018	19.95	4,120	—	Peak streamflow indicated for this event is maximum prior to backwater from Waccamaw River.
49	02110500	WACCAMAW RIVER NEAR LONGS, SC	33°54'45"	78°42'55"	NAD27	1,110	9/22/1999 (Hurr Floyd)	17.94	28,200	1951-2017	1 / 68	9/20/2018	20.22	57,500	—	Tidally influenced, which is overcome by basin runoff at high flows.
50	02110704	WACCAMAW RIVER AT CONWAY MARINA AT CONWAY, SC	33°49'58"	79°02'38"	NAD27	1,440	9/25/1999 (Hurr Floyd)	17.64	24,100	1995-2017	1 / 24	9/26/2018	21.16	49,000	11	
51	02120780	SECOND CREEK NEAR BARBER, NC	35°43'03"	80°35'45"	NAD83	118	8/28/1995	17.28	8,560	1980-2017	4 / 39	9/17/2018	15.87	5,270	19	
52	0212430293	REEDY CREEK BELOW I-485 NR PINE RIDGE, NC	35°15'31"	80°39'46"	NAD83	12.6	8/27/2008	15.08	4,500	2008-17	4 / 11	9/16/2018	11.30	1,510	15	
53	0212430653	MCKEE CREEK AT SR2804 NR WILGROVE, NC	35°15'14"	80°38'53"	NAD83	5.76	8/27/2008	9.94	1,510	2008-17	4 / 11	9/16/2018	8.14	917	14	
54	0212466000	CLEAR CREEK AT SR3181 NR MINT HILL, NC	35°12'30"	80°34'48"	NAD83	12.6	9/28/2004	10.92	2,160	2004-17	2 / 15	9/16/2018	10.02	1,890	15	
55	0212467595	GOOSE CREEK AT SR1525 NR INDIAN TRAIL, NC	35°07'30"	80°36'10"	NAD83	11	8/19/2015	11.92	4,960	2004-17	3 / 15	9/16/2018	9.84	2,990	7.5	
56	02126000	ROCKY RIVER NEAR NORWOOD, NC	35°08'56"	80°10'33"	NAD83	1,372	9/18/1945	46.37	105,000	1908; 1930-2017	2 / 90	9/16/2018	44.50	95,000	20	Peak stage from survey of high-water mark in streamgage house. Peak streamflow is second highest since historic peak of 67,600 ft ³ /s in August 1908.

Table 1. Preliminary peak stage and streamflow data at streamgages in North Carolina and South Carolina with at least 10 years of record and where new or top 5 peak streamflow record was set during the flood of September 2018 following Hurricane Florence.—Continued

[USGS, U.S. Geological Survey; °, degrees; ', minutes; ", seconds; NAD27, North American Datum of 1927; NAD83, North American Datum of 1983; mi², square miles; ft, feet; ft³/s, cubic feet per second; —, data not available; n/a, not applicable; n/d, not determined; Hurr, hurricane. Yellow shading indicates streamgages for which the September 2018 flood peak was the new peak of record; no shading indicates streamgages that recorded peaks that ranked in the top 5 for the period of record; tan shading indicates stage-only sites that recorded peak stage records. Period of record is given in water years, which is the period October 1–September 30 and is identified by the year in which the period ends. Number of annual peak streamflows in record used for rank comparison includes the preliminary 2018 water year peak associated with the September 2018 flood]

Site index number (fig. 5)	USGS station number	Station name	Latitude	Longitude	Horizontal datum	Contributing drainage area, in mi ²	Flood data				National Weather Service flood stage, in ft	Remarks				
							Previous maximum		Period of record for annual peak streamflows	Flood of September 2018						
							Date of peak streamflow	Peak stage, in ft		Peak streamflow, in ft ³ /s			Rank / number of annual peak streamflows in record	Date of peak streamflow	Peak stage, in ft	Peak streamflow, in ft ³ /s
Yadkin-Pee Dee River Basin—Continued																
57	02128000	LITTLE RIVER NEAR STAR, NC	35°23'14"	79°49'53"	NAD83	106	7/23/1997	18.60	15,400	1955-2017	1 / 64	9/17/2018	28.80	33,000	14	Peak stage based on max of three high-water marks surveyed at site following runoff event; peak streamflow determined from indirect measurement.
58	02129000	PEE DEE R NR ROCKINGHAM, NC	34°56'45"	79°52'11"	NAD83	6,863	8/27/1908	31.28	276,000	1907-11; 1928-2017	4 / 96	9/17/2018	24.38	196,000	15	Streamflow regulated since 1928 by Blewett Falls Lake and five other reservoirs upstream.
59	02130561	PEE DEE RIVER NR BENNETTSVILLE, SC	34°36'22"	79°47'19"	NAD27	7,600	4/12/2003	89.94	124,000	1992-2017	1 / 27	9/18/2018	93.06	192,000	—	Streamflow regulated by powerplants above station.
60	02130840	BLACK CREEK BELOW CHESTER-FIELD, SC	34°39'48"	80°12'42"	NAD83	51.7	11/23/2006	10.07	1,480	2006-17	1 / 13	9/17/2018	11.99	3,690	14	
61	02130900	BLACK CREEK NEAR MCBEE, SC	34°30'50"	80°11'00"	NAD27	108	10/12/1990	13.07	4,500	1960-2017	1 / 59	9/17/2018	13.39	4,940	15	
62	02130910	BLACK CREEK NEAR HARTSVILLE, SC	34°23'50"	80°09'00"	NAD27	173	10/13/1990	12.35	4,450	1961-2017	1 / 58	9/17/2018	13.47	5,270	—	Some regulation by storage in Lake Robinson above station.
63	02130980	BLACK CREEK NEAR QUINBY, SC	34°14'37"	79°44'42"	NAD27	438	10/4/2015 (Hurr Joaquin)	16.81	6,530	2002-17	1 / 17	9/17/2018	17.37	6,880	10	Some regulation by storage in Lake Robinson above station.
64	02131000	PEE DEE RIVER AT PEEDEE, SC	34°12'15"	79°32'55"	NAD27	8,830	9/22/1945	33.30	220,000	1939-2017	2 / 80	9/21/2018	31.83	132,000	19	Streamflow regulated by six powerplants above station.
65	02131010	PEE DEE RIVER BELOW PEE DEE, SC	34°09'26"	79°33'13"	NAD27	8,850	4/16/2003	33.96	99,000	1997-2017	1 / 22	9/21/2018	36.96	139,000	—	Streamflow regulated by six powerplants above station.
66	02131500	LYNCHES RIVER NEAR BISHOPVILLE, SC	34°15'00"	80°12'50"	NAD27	675	9/19/1945	22.35	29,400	1943-2017	2 / 76	9/18/2018	18.22	18,000	—	
67	02132320	BIG SHOE HEEL CREEK NR LAURINBURG, NC	34°45'02"	79°23'12"	NAD83	83.3	10/10/2016 (Hurr Matthew)	6.26	1,480	1988-2017	1 / 31	9/17/2018	9.49	6,090	14	

Table 1. Preliminary peak stage and streamflow data at streamgages in North Carolina and South Carolina with at least 10 years of record and where new or top 5 peak streamflow record was set during the flood of September 2018 following Hurricane Florence.—Continued

[USGS, U.S. Geological Survey; °, degrees; ', minutes; ", seconds; NAD27, North American Datum of 1927; NAD83, North American Datum of 1983; mi², square miles; ft, feet; ft³/s, cubic feet per second; —, data not available; n/a, not applicable; n/d, not determined; Hurr, hurricane. Yellow shading indicates streamgages for which the September 2018 flood peak was the new peak of record; no shading indicates streamgages that recorded peaks that ranked in the top 5 for the period of record; tan shading indicates stage-only sites that recorded peak stage records. Period of record is given in water years, which is the period October 1–September 30 and is identified by the year in which the period ends. Number of annual peak streamflows in record used for rank comparison includes the preliminary 2018 water year peak associated with the September 2018 flood]

Site index number (fig. 5)	USGS station number	Station name	Latitude	Longitude	Horizontal datum	Contributing drainage area, in mi ²	Flood data				Remarks				
							Previous maximum		Period of record for annual peak streamflows	Flood of September 2018			National Weather Service flood stage, in ft		
							Date of peak streamflow	Peak stage, in ft		Peak streamflow, in ft ³ /s		Rank / number of annual peak streamflows in record		Date of peak streamflow	Peak stage, in ft
Yadkin-Pee Dee River Basin—Continued															
68	02132500	LITTLE PEE DEE RIVER NEAR DILLON, SC	34°24'17"	79°20'25"	NAD27	524	10/12/2016 (Hurr Matthew)	16.41	n/a	n/a	9/18/2018	18.27	n/a	—	Operated as a rapid deployment gage during passage of Hurricane Florence. Peak stage determined based on maximum observed elevation (93.41 ft) adjusted by gage datum (75.14 ft) for streamgage.
69	02133500	DROWNING CREEK NEAR HOFFMAN, NC	35°03'40"	79°29'38"	NAD83	183	9/18/1945	10.29	10,900	1940-2017	9/17/2018	11.49	10,000	8	
70	02133624	LUMBER RIVER NEAR MAXTON, NC	34°46'22"	79°19'55"	NAD83	365	10/11/2016 (Hurr Matthew)	15.49	6,790	1988-92; 1994-2017	9/19/2018	20.61	22,200	—	
71	02134170	LUMBER RIVER AT LUMBERTON, NC	34°37'13"	79°00'40"	NAD83	708	10/10/2016 (Hurr Matthew)	21.87	14,600	2001-17	9/17/2018	22.21	17,100	13	
72	02134480	BIG SWAMP NR TAR HEEL, NC	34°42'37"	78°50'11"	NAD83	229	10/9/2016 (Hurr Matthew)	18.72	19,400	1986-2017	9/17/2018	17.25	13,300	16	
73	02134500	LUMBER RIVER AT BOARDMAN, NC	34°26'33"	78°57'37"	NAD83	1,228	10/11/2016 (Hurr Matthew)	14.41	38,200	1901; 1905-06; 1908-10; 1928; 1930-2017	9/18/2018	14.37	37,600	—	
74	02135000	LITTLE PEE DEE R. AT GALIVANTS FERRY, SC	34°03'25"	79°14'50"	NAD27	2,790	10/12/2016 (Hurr Matthew)	17.10	59,300	1942-2017	9/21/2018	17.21	66,900	9	Based on a historic floodmark, the September 2018 peak is likely the largest since at least 1928.
75	02135200	PEE DEE RIVER AT HWY 701 NR BUCKSPORT, SC	33°39'39"	79°09'17"	NAD27	14,100	10/16/2016 (Hurr Matthew)	22.60	124,000	2003-13; 2015-17	9/26/2018	25.00	136,000	—	Regulated; tidally influenced, which is overcome by basin runoff at high flows

Table 1. Preliminary peak stage and streamflow data at streamgages in North Carolina and South Carolina with at least 10 years of record and where new or top 5 peak streamflow record was set during the flood of September 2018 following Hurricane Florence.—Continued

[USGS, U.S. Geological Survey; °, degrees; ', minutes; ", seconds; NAD27, North American Datum of 1927; NAD83, North American Datum of 1983; mi², square miles; ft, feet; ft³/s, cubic feet per second; —, data not available; n/a, not applicable; n/d, not determined; Hurr, hurricane. Yellow shading indicates streamgages for which the September 2018 flood peak was the new peak of record; no shading indicates streamgages that recorded peaks that ranked in the top 5 for the period of record; tan shading indicates stage-only sites that recorded peak stage records. Period of record is given in water years, which is the period October 1–September 30 and is identified by the year in which the period ends. Number of annual peak streamflows in record used for rank comparison includes the preliminary 2018 water year peak associated with the September 2018 flood]

Site index number (fig. 5)	USGS station number	Station name	Latitude	Longitude	Horizontal datum	Contributing drainage area, in mi ²	Flood data				National Weather Service flood stage, in ft	Remarks				
							Previous maximum		Period of record for annual peak streamflows	Flood of September 2018						
							Date of peak streamflow	Peak stage, in ft		Peak streamflow, in ft ³ /s			Rank / number of annual peak streamflows in record	Date of peak streamflow	Peak stage, in ft	Peak streamflow, in ft ³ /s
Catawba-Santee River Basin																
76	02146348	COFFEY CREEK NR CHARLOTTE, NC	35°08'45"	80°55'37"	NAD83	9.14	8/27/2008	12.11	1,640	1999; 2000-17	4/20	9/16/2018	11.11	1,140	13	
77	02146381	SUGAR CREEK AT NC 51 NEAR PINEVILLE, NC	35°05'27"	80°53'58"	NAD83	65.3	7/23/1997	18.68	9,890	1995-2017	2/24	9/16/2018	15.59	6,620	18	
78	02146530	LITTLE SUGAR CREEK AT PINEVILLE, NC	35°05'07"	80°52'56"	NAD83	49.2	7/23/1997	23.04	11,200	1966-68; 1997-2017	4/25	9/16/2018	18.42	6,790	18	
79	0214655255	MICALPINE CREEK AT SR3150 NR IDLEWILD, NC	35°10'33"	80°43'09"	NAD83	7.33	6/7/2003	13.32	5,600	1999; 2001; 2003-17	5/18	9/16/2018	7.71	1,640	16.5	
80	0214657975	IRVINS CREEK AT SR3168 NR CHARLOTTE, NC	35°09'31"	80°42'48"	NAD83	8.37	6/18/2003	10.27	2,670	1999; 2000-17	3/20	9/16/2018	9.61	2,200	13	
81	02146600	MICALPINE CR AT SARDIS ROAD NEAR CHARLOTTE, NC	35°08'16"	80°46'03"	NAD83	38.6	8/27/1995	17.79	9,040	1962-2017	2/57	9/16/2018	17.68	8,500	20	Estimated peak streamflow based on provisional rating-curve extension.
82	02146750	MICALPINE CR BELOW MCMULLEN CR NR PINEVILLE, NC	35°03'59"	80°52'11"	NAD83	92.4	8/27/1995	19.40	12,500	1975-2017	2/44	9/16/2018	18.65	12,000	18	
83	02146800	SUGAR CREEK NEAR FORT MILL, SC	35°00'21"	80°54'09"	NAD27	262	8/27/2008	27.30	19,300	2007-17	2/12	9/17/2018	27.23	19,200	27	
Tennessee River Basin																
84	0344894205	NORTH FORK SWANNANOA RIVER NEAR WALKERTOWN, NC	35°41'07"	82°19'58"	NAD83	14.5	9/8/2004	10.33	7,000	1989-2017	4/30	9/16/2018	6.70	3,090	—	

¹The peak streamflow and stage data for September 2018 are provisional and, therefore, subject to change.

Manuscript was approved on October 23, 2018

For more information about this publication, contact

Director
South Atlantic Water Science Center
U.S. Geological Survey
720 Gracern Road
Columbia, SC 29210
(803) 750-6100

For additional information visit <https://www.usgs.gov/centers/sa-water>

Prepared by the USGS Science Publishing Network,
Reston Publishing Service Center





Pee Dee River Basin Bridge Evaluation Hurricane Florence



September 18, 2018



**INFRASTRUCTURE
ENGINEERS**

ingenuity & agility

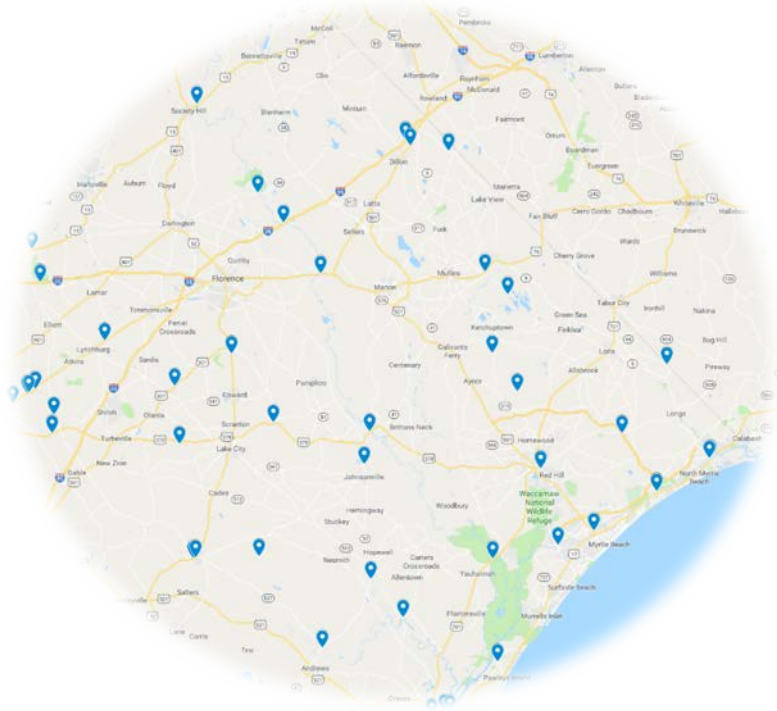

BACKGROUND

Hurricane Florence impacted the coast of North Carolina and South Carolina during September 14 – 16, 2018. Historical amounts of rainfall fell in parts of North Carolina and northeastern South Carolina, significantly impacting the rivers in the Pee Dee River Basin. In South Carolina, the Pee Dee River Basin includes the following rivers:

Great Pee Dee River

Little Pee Dee River

Waccamaw River

Lynches River

Black River

OBJECTIVE

Since 2009 Infrastructure Engineers (since 1998 for Jeff Rowe) has been involved in the underwater inspections of SCDOT Bridges. Based on our knowledge, resources and research, we have put together the following document to help determine the impact of rising waters in the rivers of the Pee Dee Basin. The information presented is a summation of the most current underwater inspection reports; available plans (those that Infrastructure Engineers has in our plan library); USGS and NOAA stream gauge data; and engineering evaluation of the data. There have not been any field investigations performed to date and the hope is this document will help guide the SCDOT to prioritize field investigations and monitoring of bridges in the basin.

Great Pee Dee River

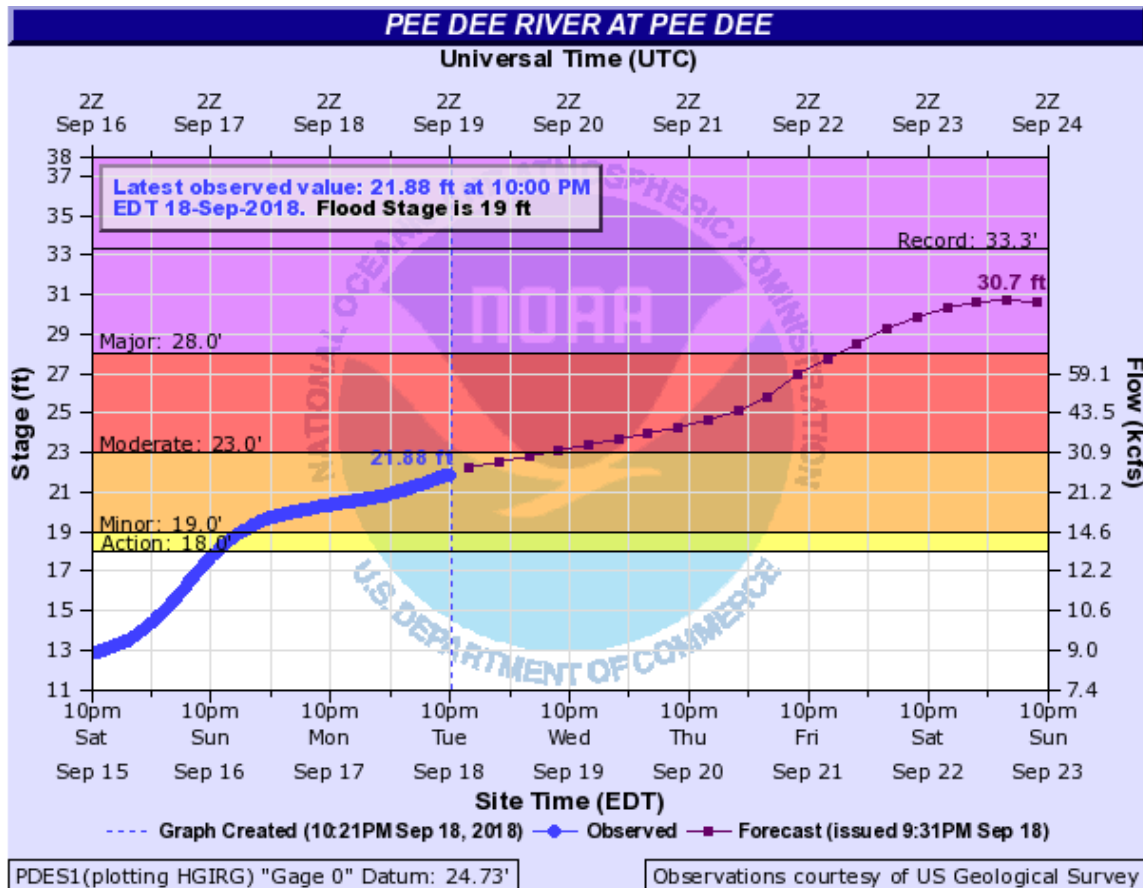

The Great Pee Dee River is projected to crest this weekend close to historical levels of 1945.

The following are bridges located in Great Pee Dee River that are included in the underwater inspection program and the last underwater inspection date is shown.

2110009511600	5045	Florence	November 3, 2016	I-95 NBL	Great Pee Dee River
2110009531600	5051	Florence	March 8, 2016	I-95 SBL	Great Pee Dee River
3420007620100	3923	Marion	September 18, 2016	US 76 EBL	Great Pee Dee River
3420007640100	8579	Marion	September 18, 2016	US 76 WBL	Great Pee Dee River
3420037800100	2216	Marion	September 18, 2016	US 378	Great Pee Dee River
3520000110100	3928	Marlboro	September 15, 2016	US 1 NBL	Great Pee Dee River
3520000130100	889	Marlboro	September 15, 2016	US 1 SBL	Great Pee Dee River
3520001500100	1391	Marlboro	September 15, 2016	US 15	Great Pee Dee River
3540003400100	8902	Marlboro	June 13, 2012	SC 34	Great Pee Dee River
2220001700500	5061	Georgetown	October 16, 2016	US 17	Pee Dee River
2220070100500	2034	Georgetown	April 25, 2013	US 701	Pee Dee River

I-95 NB over the Great Pee Dee River

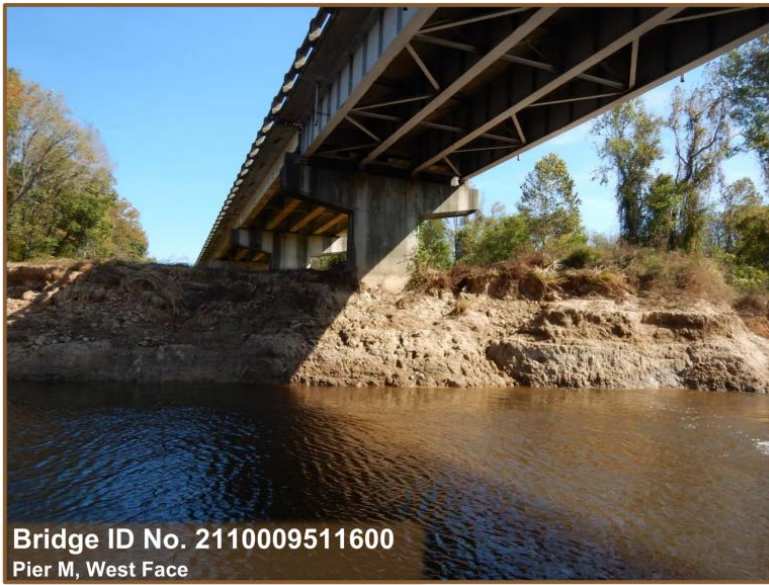

I-95 NB over the Great Pee Dee has been monitored over the last couple of year due to the significant migration of the channel towards the north abutment. When the bridge was constructed in the mid-1960's Piers O and P were located in the center of the river channel. Now with the migration, Pier N is located in the middle of the channel and Pier M is at the edge of the channel, with the potential for Pier L to be exposed as well. Currently the footing of Pier N is undermined with timber piles exposed.

Concern – During the flooding the channel bank at Pier M will erode exposing the footing and ultimately undermining the footing. The footing of Pier M is 10 ft higher than Pier N. There is also a potential that Pier L may be impacted and the footing of Pier L is 10 ft higher than Pier M.

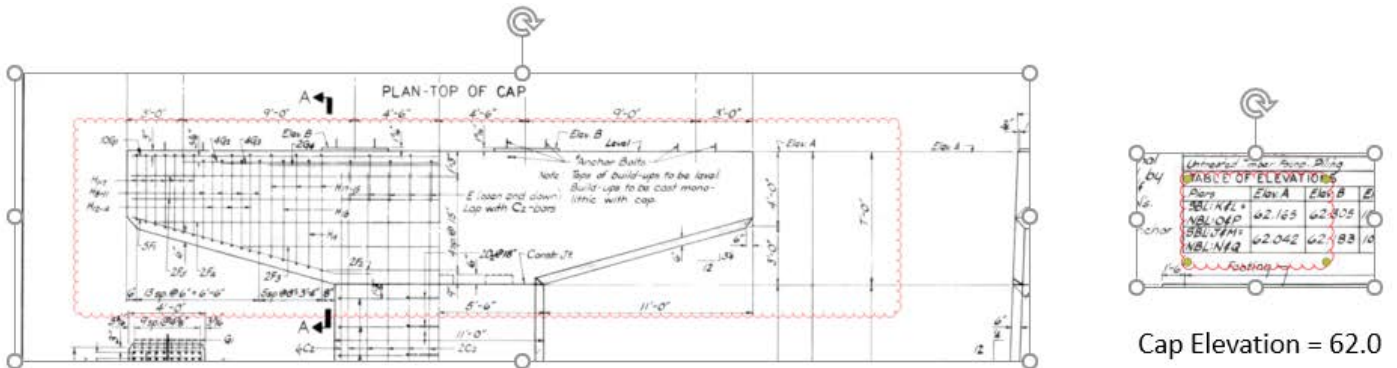

I-95 NB – Pier N

Concern – According to the gauge on I-95 SB, the water level at 10pm on 9/18 is 52.3 ft, less than 10 ft from the top of the Cap at Pier N. NOAA indicates that the river will rise an additional 9 ft, bringing the water level very close to the top of the cap and bottom of the superstructure.

I-95 SB over the Great Pee Dee River



Unlike I-95 NB, the migration of the channel has not been as significant at the SB bridge. At the time of construction Piers J and K were located in the main portions of the channel. Today they are still located in the channel. There is seal exposure of up to 3 ft. at Pier K, but no undermining as of the 2016 inspection.

Concern – Flooding would cause additional undermining of Pier K, exposing the timber piles.

Without
anal
2, by
of
cols.
Anchor

Rainforcing Steel
Untreated Timber Found. Piling

TABLE OF ELEVATIONS		
Piers	Elev. A	Elev. B
SBL:K&L =	62.165	62.305
SBL:J&M =	62.042	62.183
NBL:N&Q		

Footings

Concern – According to the gauge on I-95 SB, the water level at 10pm on 9/18 is 52.3 ft, less than 10 ft from the top of the Cap at Pier J. NOAA indicates that the river will rise an additional 9 ft, bringing the water level very close to the top of the cap and bottom of the superstructure.

US 76 EB & WB over the Great Pee Dee River



EB

Foundation – Footing/Seal/Timber Piles

Footing Exposure – Pier B up to 1.5 high

Remaining Footing & Seal - 7.5'
bottom of seal at Elev. 12.8 @ Pier B

Clearance

FG @ Pier B= 67.5

Top of Cap Pier B = 56.8

1945 Flood Elevation = 58.6

Concerns = Overtopping of the Pier Cap



WB

Foundation – Footing/Seal/Steel H-Piles

Footing Exposure – None

Remaining Footing & Seal >17'
bottom of seal at Elev. -9.5 @ Pier B

Clearance

FG @ Pier B= 69.7

Top of Cap Pier B = 61.2

1945 Flood Elevation = 58.6 (from EBL)

Concerns = Overtopping of the Pier Cap

US 378 over the Great Pee Dee River



Foundation – Drilled Shafts

Clearance

FG @ Bent 3= 65.3

Top of Cap Pier B = 57.3

100 Yr Flood Elevation = 40.63

Concerns = None

US 1 NB & SB over the Great Pee Dee River

River may have already crested at these bridges



NB

Foundation – Spread footing keyed in rock

Footing Exposure – Undermining at Pier C up to 15" high x 12" penetration

Bottom of footing at Elev. 13.9 @ Pier C

Clearance

FG @ Pier C = 82.8

Top of Cap Pier C = 73.9

1908 Flood Elevation = 74.0

**Concerns = Overtopping of the Pier Cap –
Undermining of Footings**



SB

Foundation – Spread footing keyed in rock

Footing Exposure – Undermining at Pier D up to 4" high x 22" penetration

Bottom of footing at Elev. (no plans)

Clearance

FG @ Pier (no plans)

Top of Cap Pier (no plans)

1908 Flood Elevation = 74.0 (NBL Plans)

**Concerns = Overtopping of Pier Cap –
Undermining of Footings**

US 15 over the Great Pee Dee River



Foundation – Drilled Shafts

Clearance

FG @ Bent 10= 99.4

Top of Cap Bent 10= 91.38

100 Yr Flood Elevation = Not shown on plans

Concerns = None

SC 34 over the Great Pee Dee River



Foundation – Drilled Shafts

Clearance

FG @ Pier D= 79.7

Top of Cap Pier D = Not available

100 Yr Flood Elevation = Not shown on plans

Concerns = None

US 701 over the Great Pee Dee River

Not sure if the new bridge has been opened to traffic



OLD Bridge

Foundation – Footing/seal/timber piles

Footing Exposure – 8' of seal exposure at Pier F

Bottom of footing at Elev. -31.8 @ Pier F

Clearance

FG @ Pier F = 46.1

Concern = Undermining of Footings – however large number of piles



New Bridge

Foundation – Drilled shafts

No plans available on the new bridge.

Concerns = None

Little Pee Dee River

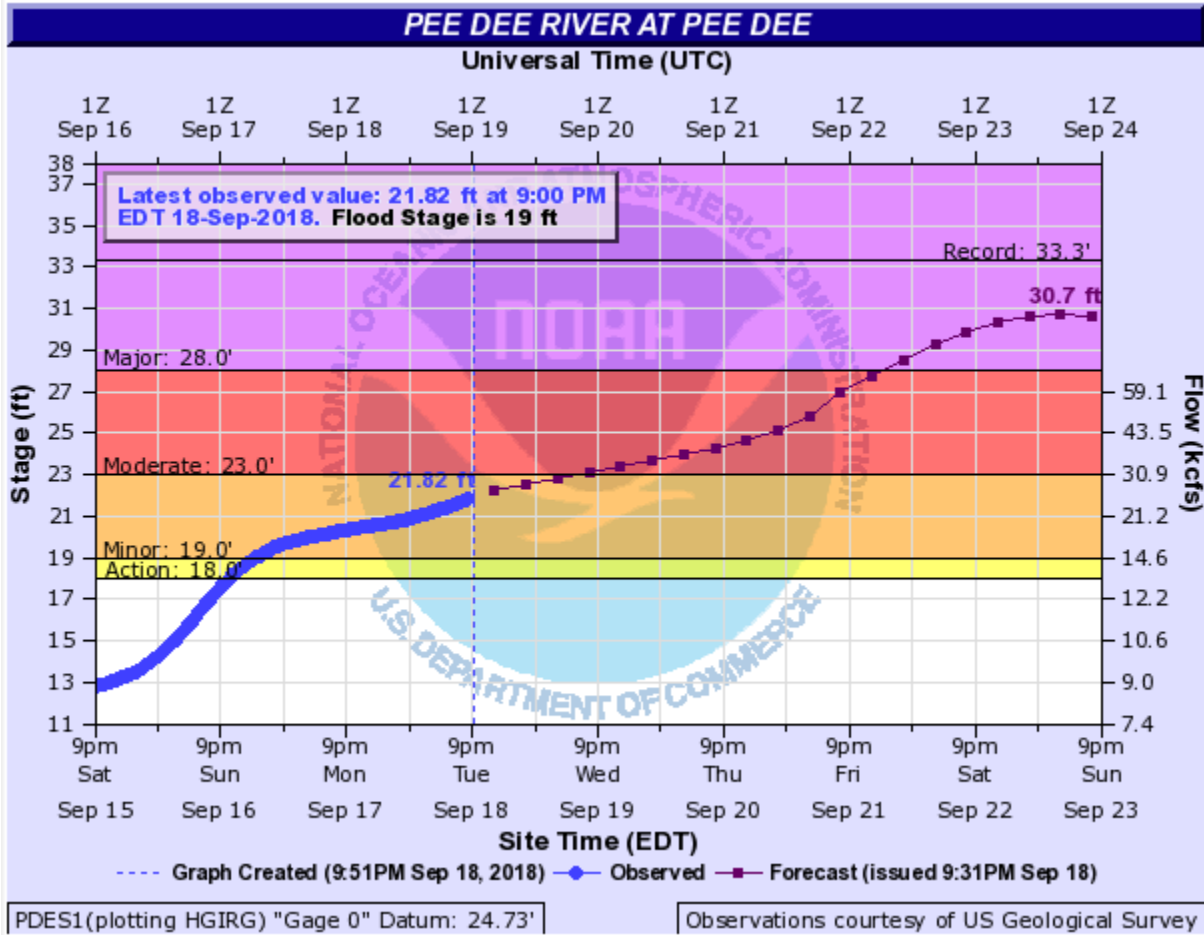

The Little Pee Dee River is expected to crest at 30.7 ft. This is close to the historic flood of 1928. Many of the bridge plans reference the 1928 flood.

It should be noted that the NOAA gauge located downstream from the inlet with the Lumberton River, so it is hard to determine the actual flows at the bridge. Some of the projected high water levels discussed below may actually be less since it is based on the NOAA projected data.

The following are bridges located on the Little Pee Dee River that are included in the underwater inspection program and the last underwater inspection date is shown

1710009510900	5280	Dillon	April 26, 2013	I-95 NBL	Little Pee Dee River
1710009530900	5281	Dillon	April 26, 2013	I-95 SBL	Little Pee Dee River
1720030100400	1184	Dillon	March 8, 2016	US 301	Little Pee Dee River
3420007600700	45	Marion	June 13, 2016	US 76	Little Pee Dee River

I-95 over the Little Pee Dee River



NBL

Foundation – Concrete Piles

Pile Exposure ~ 23'

Pile length = ~45'

Clearance

FG @ Bent 7= 108.5

Top of Cap Bent 7 = 106.4

1928 Flood Elevation = 103.0

Concerns = Water is projected to come within ~3' of the top of Cap.

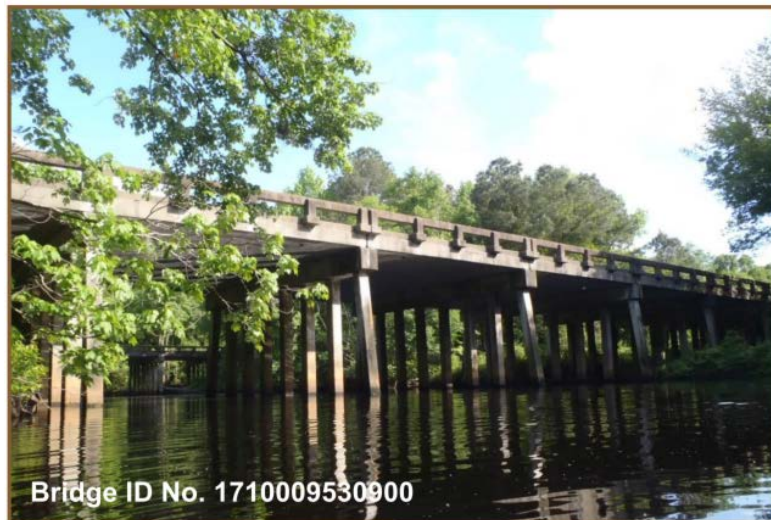

SBL

Foundation – Concrete Piles

Pile Exposure ~ 25'

Pile length = ~45'

Clearance

FG @ Bent 7= 108.5

Top of Cap Bent 7 = 106.4

1928 Flood Elevation = 103.0

Concerns = Water is projected to come within ~3' of the top of Cap.

US 301 over the Little Pee Dee River



Foundation – Concrete Piles

Pile Exposure ~ 17'

Pile length = Unknown (plans may indicate greater than 20')

Clearance

FG @ Bent 13= 102.0

Top of Cap Bent 13 = 99.5

1928 Flood Elevation = 98.4

Concerns = Water is projected to come within ~1' of the top of Cap.

US 76 over the Little Pee Dee River



Foundation – Footing/seals/piles(?) – steel piles for overhangs – no available plans

Seals exposed up to 0.7'

Clearance

No available plans, however normal waterline to top of cap is ~ 13'

Concerns = Water is projected to come within ~2' (11' rise) of the top of Cap. – need to review plans to verify.

Waccamaw River

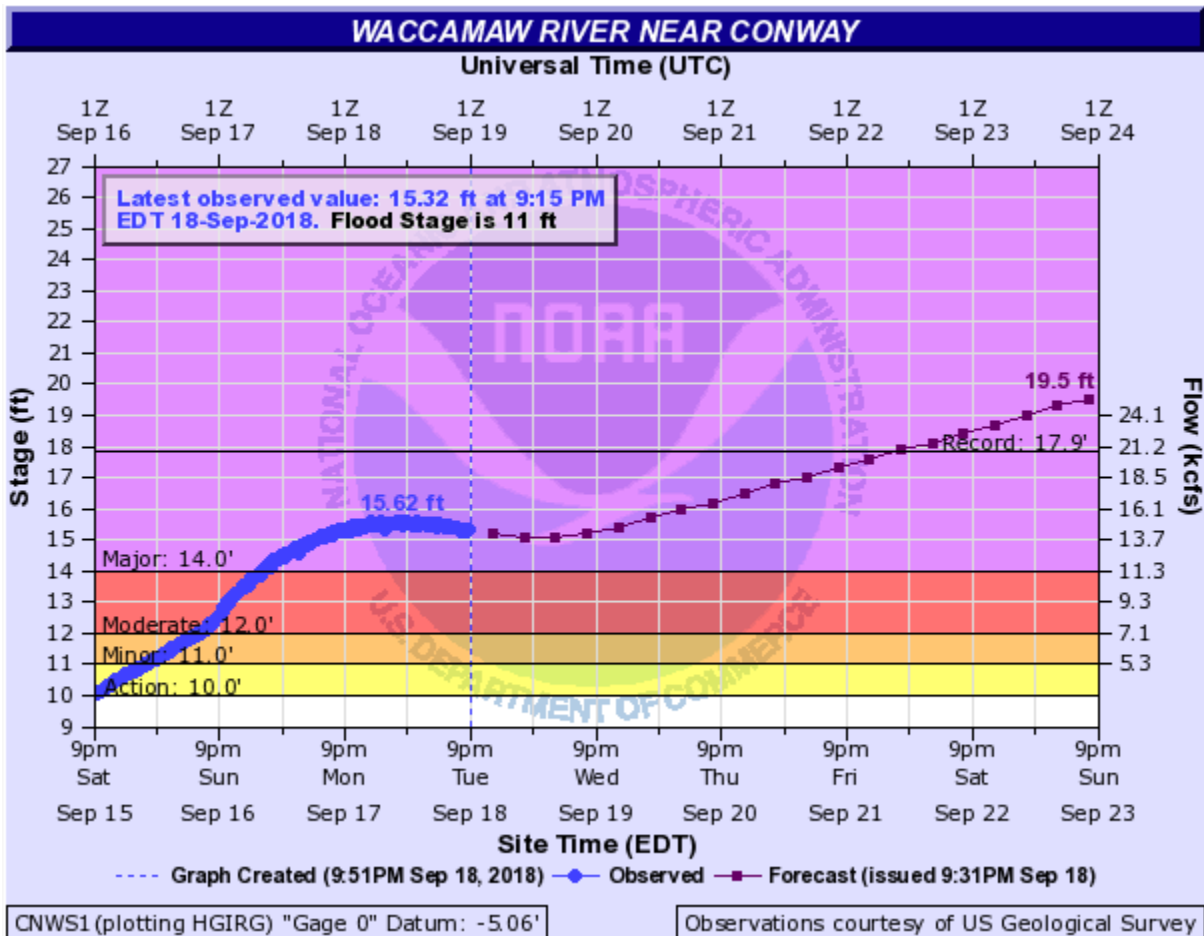

The Waccamaw River is projected to significantly crest well above the record flood level of October 2016. We do not have plans in our plans library for a number of the bridges listed below; however, there is limited risk of water overtopping the pier caps and only one structure has footing exposure.

The following are bridges located over the Waccamaw River that are included in the underwater inspection program and the last underwater inspection date is shown.

2220001700600	4792	Georgetown	July 29, 2016	US 17	Waccamaw River
2620050105200	2753	Horry	March 16, 2016	US 501 BYP	Waccamaw River
2640002221200	9696	Horry	March 14, 2016	SC 22 EBL	Waccamaw River
2640002241200	9697	Horry	March 15, 2016	SC 22 WBL	Waccamaw River
2620050103100	793	Horry	March 15, 2016	US 501	Waccamaw River & SCLR

US 501 over the Waccamaw River

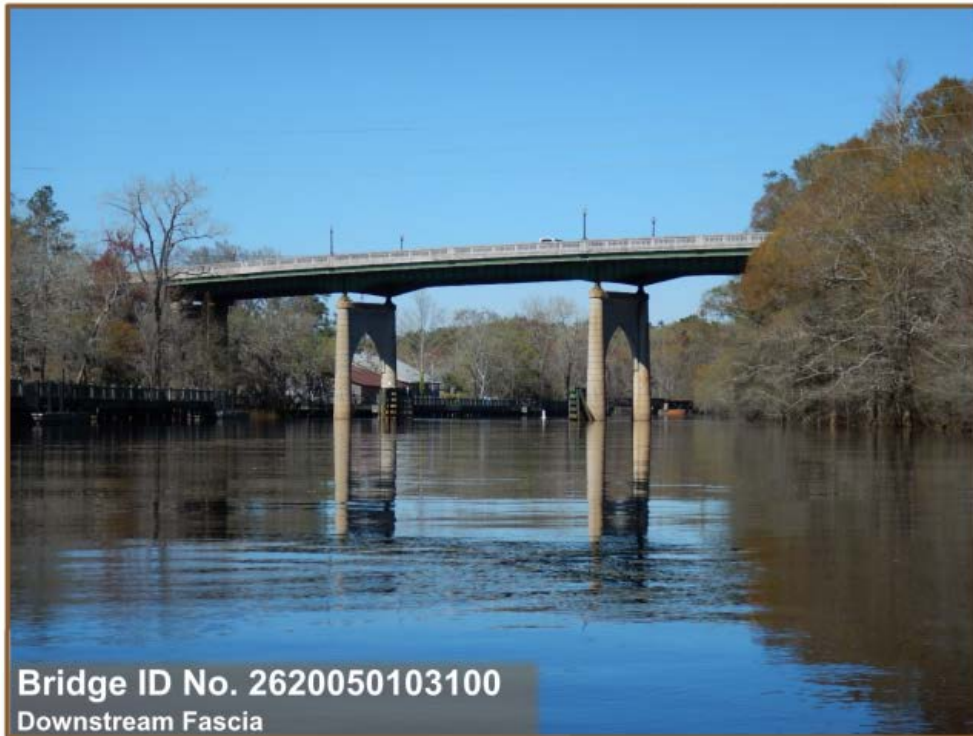

Foundation – Footing and timber piles

No footing exposure – no plans for elevations

Clearance – over 50' from normal water level to FG – no plans available

Concerns = None

US 501 BYP over the Waccamaw River



Foundation – Footing and timber piles

Footing exposure up to 3.5' high Pier 11– no plans for elevations

Clearance – over 35' from normal water level to FG – no plans available

Concerns = undermining of footing – need to review plans

SC 22 over the Waccamaw (EB & WB) River



Foundation –Drilled Shafts ? – No plans available for confirmation/elevations

Clearance – over 30' from normal water level to FG – no plans available

Concerns = None

US 17 over the Waccamaw River

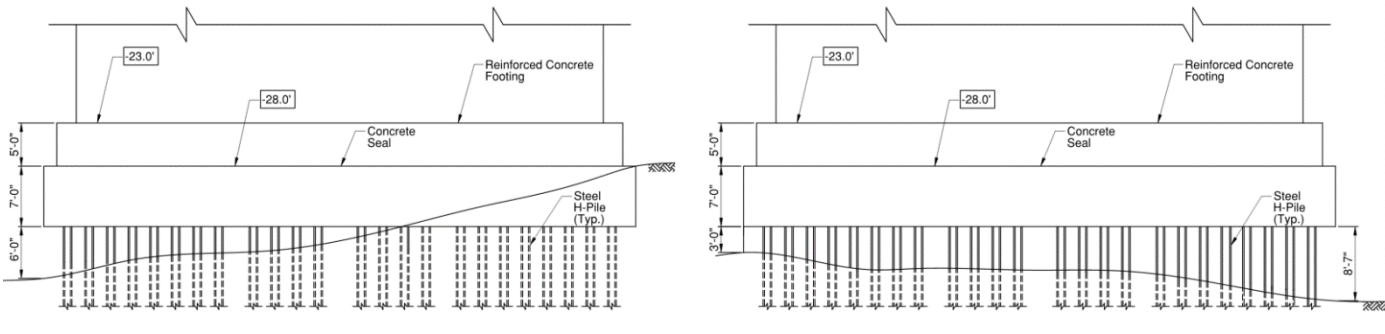
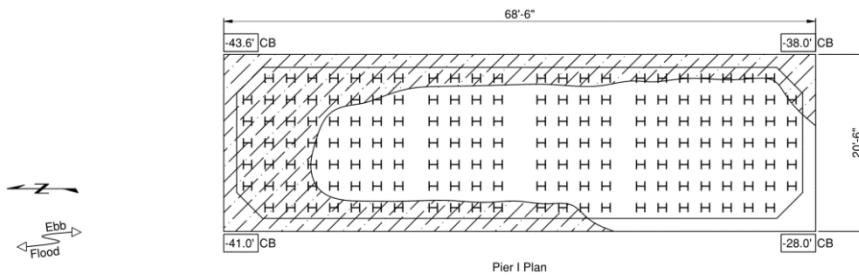

Foundation –Footing/Seal/Steel Piles

Undermining up to 8.5' on Pier I

Concerns = No concerns during the flooding, however, extreme flows may cause additional significant undermining of the Piers. 8.5' is from the 2016 inspection, so it could have even increased more since then and may be significantly deeper after the flood.



Lynches River

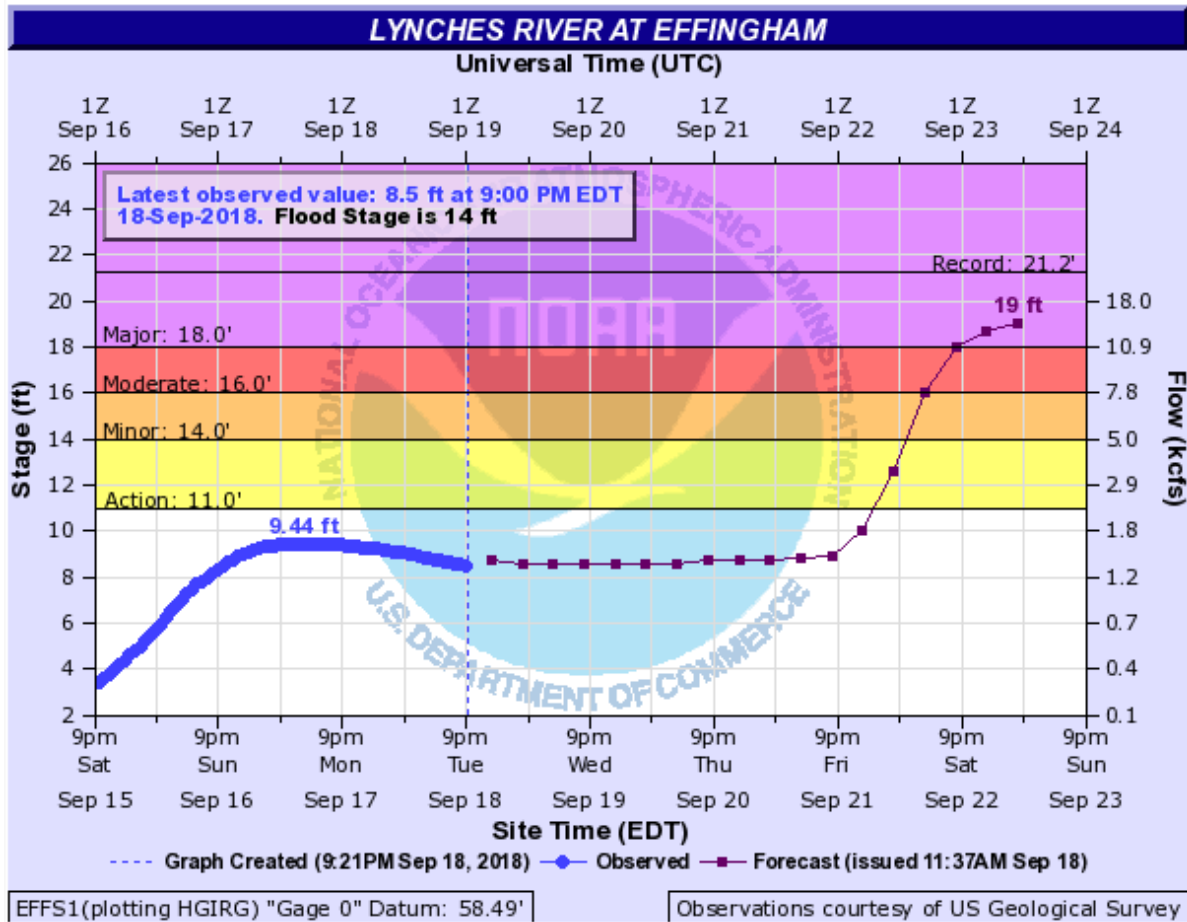

The hydrograph for the Lynch River indicates an initial crest of 9.44 ft. on Monday and it has leveled off. However, it is showing that later this week it will dramatically increase to major flood stage. Looking at the river basin it is difficult to understand the dramatic increase later this week, unless there is a scheduled release of water from the reservoir located at the headwaters of the Lynch River.

Even with the projected increase to major flood status, the river level will still be below the crest in October 2015. Furthermore all of the bridges over the Lynch River (except one) – US 52, US 76, US 301, US 378, SC 41 and I-20 are founded on either concrete piles or drilled shafts. US 15 over the Lynch River is founded on a footing/seal/pile foundation, however, there is significant cover over the footing.

Concern – None, unless the river is projected to go higher or there were significant problems of overtopping at any of the bridges during the flood of October 2015

Black River

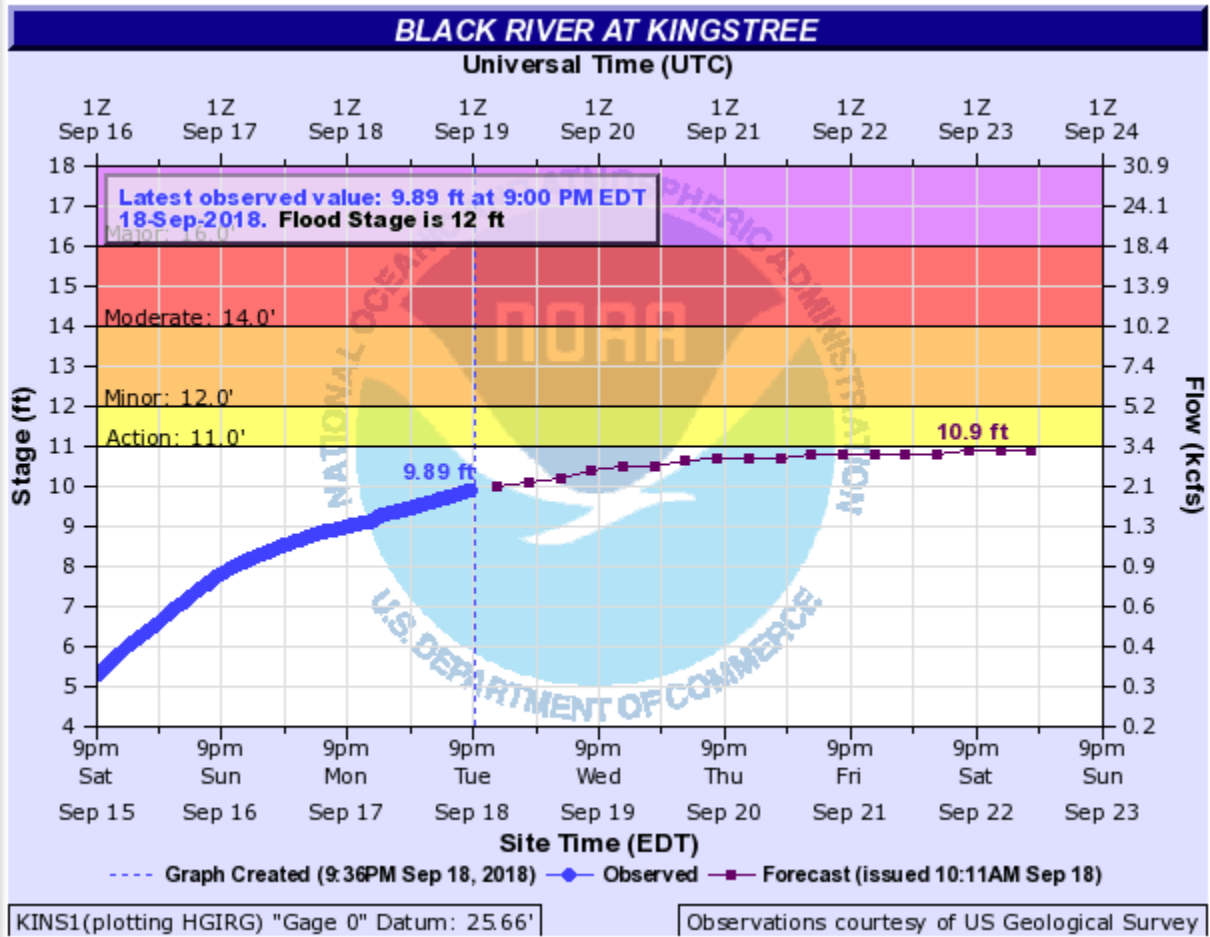

The hydrograph for the Black River indicates a crest this weekend of 10.9 ft, well below flood stage and over 12 ft below the historic levels of October 2015. Because of this, there is no concern for any of the structures spanning the Black River (S-22-179, US 378, US 52 or US 41) as well as the I-95 structures which were significantly impacted in 2015.

Concern – None